



Instruction Manual



mini CORI-FLOW ML120 (Ultra) Low Flow Coriolis Mass Flow Meters / Controllers

Doc. no.: 9.17.097 rev. K Date: 23-09-2020



ATTENTION

Please read this document carefully before installing and operating the product.
Not following the guidelines could result in personal injury and/or damage to the equipment.



Copyright

© 2020 Bronkhorst High-Tech B.V.

All rights reserved. No part of this publication may be reproduced, distributed, or transmitted in any form or by any means, without the prior written permission of the publisher.

Disclaimer

This document has been reviewed and is believed to be accurate. Bronkhorst High-Tech B.V. does not assume liability for errors, inaccuracies or absence of information. The material in this document merely serves information and illustration purposes; no rights can be derived from its contents.

Bronkhorst High-Tech B.V. reserves the right to modify or improve its products and documentation without informing anyone. As such, the information contained in this document is subject to change without notice. Device specifications and the contents of the package may deviate from what is stated in this document.

Symbols in this document



Important information. Disregarding this information could increase the risk of damage to the equipment, or the risk of personal injuries.



Helpful information. This information will facilitate the use of the instrument and/or contribute to its optimal performance.



Additional information available on the internet or from your Bronkhorst representative.

Receipt of equipment

Check the outside packaging box for damage incurred during shipment. If the box is damaged, the local carrier must be notified at once regarding his liability, if so required. At the same time a report should be submitted to your Bronkhorst representative.

Carefully remove the equipment from the box. Verify that the contents of the package was not damaged during shipment. Should the equipment be damaged, the local carrier must be notified at once regarding his liability, if so required. At the same time a report should be submitted to your Bronkhorst representative.



- *Check the packing list to ensure that you received all of the items included in the scope of delivery*
- *Do not discard spare or replacement parts with the packaging material*

Refer to [Removal and return instructions](#) about return shipment procedures.

Equipment storage

- The equipment should be stored in its original package in a climate controlled storage location.
- Care should be taken not to subject the equipment to excessive temperatures or humidity.
- See technical specifications for information about required storage conditions.

Warranty

Bronkhorst® products are warranted against defects in material and workmanship for a period of three years from the date of shipment, provided they are used in accordance with the ordering specifications and not subject to abuse or physical damage. Products that do not operate properly during this period may be repaired or replaced at no charge. Repairs are normally warranted for one year or the balance of the original warranty, whichever is the longer.



See also section 9 (Guarantee) of the Conditions of sales:
www.bronkhorst.com/int/about/conditions-of-sales/

The warranty includes all initial and latent defects, random failures, and indeterminable internal causes. It excludes failures and damage caused by the customer, such as contamination, improper electrical hook-up, physical shock etc.

Re-conditioning of products primarily returned for warranty service that is partly or wholly judged non-warranty may be charged for.

Bronkhorst High-Tech B.V. or affiliated company prepays outgoing freight charges when any part of the service is performed under warranty, unless otherwise agreed upon beforehand. The costs of unstamped returns are added to the repair invoice. Import and/or export charges as well as costs of foreign shipping methods and/or carriers are paid by the customer.

General safety precautions

This product is intended for use by qualified personnel who recognize shock hazards and are familiar with the safety precautions required to avoid possible injury. Read the operating information carefully before using the product.

Before operating, make sure the line cord is connected to a properly grounded power receptacle. Inspect the connecting cables for cracks or breaks before each use.

The equipment and accessories must be used in accordance with their specifications and operating instructions, otherwise the safety of the equipment may be impaired.

Opening the equipment is not allowed. There are no user serviceable parts inside. In case of a defect please return the equipment to Bronkhorst High-Tech B.V.

One or more warning signs may be attached to the product. These signs have the following meaning:



General warning; consult the instruction manual for handling instructions



Surface may get hot during operation



Shock hazard; electrical parts inside

To maintain protection from electric shock and fire, replacement components must be obtained from Bronkhorst. Standard fuses, with applicable national safety approvals, may be used if the rating and type are the same. Other components that are not safety related may be obtained from other suppliers, as long as they are equivalent to the original component. Selected parts should be obtained only through Bronkhorst, to maintain accuracy and functionality of the product. If you are unsure about the relevance of a replacement component, contact your Bronkhorst representative for information.

Table of contents

1	Introduction	7
1.1	Scope of this manual	7
1.2	Intended use	7
1.3	Product description	7
1.4	Calibration	8
1.5	Maintenance	8
1.6	Documentation	9
1.7	Model key	10
1.8	Customized I/O options	10
2	Starting up	13
2.1	Functional properties	13
2.2	Operating conditions	13
2.2.1	Tested pressure	13
2.2.2	Sealing material	13
2.3	Piping requirements	13
2.4	Mounting	14
2.5	Leak check	14
2.6	Preventing hydraulic shocks	14
2.7	Electrical connection	14
2.8	Communication interface	15
2.8.1	Analog or local interface	15
2.8.2	Digital RS232 interface	16
2.8.2.1	E-8000	16
2.8.2.2	BRIGHT	16
2.8.3	Digital RS485 interface	16
2.8.3.1	FLOW-BUS	17
2.8.3.2	Modbus	17
2.8.3.3	Other fieldbuses	18
2.9	Micro switch operation and LED indications	18
2.10	Purging before use	18
2.11	Zeroing	18
2.11.1	Zeroing using micro switch	19
2.11.2	Zeroing through digital communication	20
2.12	Powering up and powering down	20
3	Operation	21
3.1	Mass flow measurement and control	21
3.1.1	Instrument settings	21
3.1.2	Valve safe state	22
3.2	Temperature considerations	22
3.3	Analog operation	23
3.4	Basic RS232 operation	23
3.4.1	FlowDDE	24
3.4.2	Software (DDE applications)	25
3.4.3	Baud rate, node address and parity	25
3.5	Basic RS485 operation (FLOW-BUS/Modbus)	26
3.5.1	FLOW-BUS	26

3.5.2	Modbus	26
3.5.3	Software	26
3.5.4	Baud rate, node address and parity	26
3.6	Other fieldbus configurations	27
3.7	LED indications	28
3.8	Multifunctional switch	29
3.8.1	Normal operating functions	30
3.8.2	Power-up functions	30
3.8.3	Control mode - readout/change	31
3.8.4	Network settings - readout/change	31
4	Digital parameters	33
4.1	General	34
4.2	Device identification	35
4.3	Measurement and control	36
4.3.1	Advanced measurement and control	36
4.4	Alarms	38
4.5	Counter	39
4.6	Network configuration	41
4.7	Special parameters	42
4.7.1	Default control mode	44
4.8	Fluid set	44
4.8.1	Advanced fluid set parameters	45
4.9	Master/slave configuration (FLOW-BUS)	46
4.10	Controller	47
5	Batch dosing with CORI-FILL™	49
5.1	Dosing principle	49
5.1.1	Proportional control	49
5.1.2	Preventing overshoot	49
5.1.3	Estimated dosing time	50
5.2	Process conditions	50
5.3	Parameter settings	50
5.3.1	Dosing method	51
5.3.2	Batch settings	52
5.3.3	Overrun correction	53
5.3.4	Disabling filters	54
5.3.5	Proportional control settings	55
5.3.6	On/off control settings	57
5.4	Optimizing hints	58
6	Troubleshooting and service	60
6.1	Restoring factory settings	60
6.2	Common issues	60
6.3	Service	63
7	Returns	64
7.1	Removal and return instructions	64
7.2	Disposal (end of lifetime)	64
	Parameter index	65

1 Introduction

1.1 Scope of this manual

This manual contains general product information, installation and operating instructions and troubleshooting tips for the **mini CORI-FLOW ML120** series mass flow meters and controllers for liquids and gases.



1.2 Intended use

The Bronkhorst® series **mini CORI-FLOW ML120** is an accurate mass-flow meter/controller for measuring gas and liquid flows at pressures up to 200 bar(a) depending on body rating, virtually independent of pressure and temperature changes. The mini CORI-FLOW is a real mass-flow meter/controller and measures the flow in mass, it does not matter what the properties of the gases or liquids are. The system can be completed with an internal piezo control valve and a flexible readout unit to measure and control gas and liquid flows.



The wetted materials incorporated in the mini CORI-FLOW are compatible with media and conditions (e.g. pressure, temperature) as specified at ordering time. If you are planning to use the product (including any third party components supplied by Bronkhorst, such as pumps or valves) with other media and/or other conditions, always check the wetted materials (including seals) for compatibility. See the technical specifications of the product and consult third party documentation (if applicable) to check the incorporated materials.

Responsibility for the use of the equipment with regard to suitability, intended use, cleaning and corrosion resistance of the applied materials against the processed media lies solely with the end user.

Where appropriate, this document recommends or prescribes safety measures to be taken with respect to media usage or working with the described equipment under the specified conditions. The end user is responsible for taking the necessary safety precautions and proper use of appropriate (personal) protective equipment, even if such is not explicitly recommended or required in this document.

The end user is considered to be familiar with the necessary safety precautions, and to comply with the appropriate protective measures as described in the Material Safety Data Sheets of the media to be used in the system (if applicable).

Bronkhorst High-Tech B.V. cannot be held liable for any damage resulting from improper or unsafe use, use for other than the intended purpose or use with other media and/or under other conditions than specified on the purchase order.

1.3 Product description

mini CORI-FLOW ML120 instruments by Bronkhorst® are precise and compact Mass Flow Meters and Controllers for liquids and gases, based on the Coriolis measuring principle. Designed to cover the needs of the (ultra) low flow market, from 5 g/h up to 200 g/h (full scale values), the **mini CORI-FLOW** offers multi-range functionality: factory calibrated ranges can be rescaled by the user, maintaining the original accuracy specifications.

Measuring principle

Instruments of the **mini CORI-FLOW** series contain a uniquely shaped, single loop sensor tube, forming part of an oscillating system. When a fluid flows through the tube, the Coriolis force causes a phase shift, which is detected by sensors and fed into the integrated printed circuit board. The resulting output signal is proportional to the real mass flow rate, independent of fluid density, temperature, viscosity, pressure, heat capacity or conductivity. Coriolis mass flow measurement is fast, accurate and inherently bi-directional. The **mini CORI-FLOW ML120** features density and temperature of the fluid as secondary outputs.

Multi-range

The **mini CORI-FLOW ML120** offers multi-range functionality: factory calibrated ranges can be re-ranged to a different full scale range (e.g. a mini CORI-FLOW model ML120 can be used for full scale ranges between 5 g/h and 200 g/h). The analog output and the digital measured value are scaled accordingly.

Switching between ranges can be done using the RS232 interface or the fieldbus interface. For RS232 communication, Bronkhorst offers free tooling software (FlowPlot).

The instrument comes with a calibration certificate for all supported full scale ranges. The actual full scale of the instrument is set to a value as ordered and can be found on the serial number label.

Accuracy

The accuracy of a **mini CORI-FLOW** is either 0.2% reading for liquids or 0.5% reading for gases, based on mass flow (e.g. g/h, kg/h, etc.). Using the instrument for measuring volume flows (e.g. l/h, ml/min) will introduce an additional inaccuracy, based on the actual density measured by the instrument. In all instruments capable of density measurement there will be an automatic adjustment for change in density.

CORI-FILL™

mini CORI-FLOW instruments with firmware version 1.05g and up are equipped with **CORI-FILL™** technology, designed for fast and highly accurate mass or volume batch dosing of liquids or gases. The internal batch dosing controller is optimized for controlling a valve or a (gear) pump, to deliver an exact batch dose, independent of fluid properties, ambient temperature and back pressure.

1.4 Calibration

The mini CORI-FLOW is factory calibrated. Periodical inspection, recalibration or verification of the accuracy may be subject to individual requirements of the end user.

Bronkhorst certifies that the instrument meets the rated accuracy. Calibration has been performed using measurement standards traceable to the Dutch Metrology Institute (VSL).



Unless specified otherwise, **mini CORI-FLOW ML120** instruments are H₂O calibrated.

1.5 Maintenance

The mini CORI-FLOW needs no regular maintenance if operated properly, with clean media, compatible with the wetted materials, avoiding pressure and thermal shocks and vibrations. Units may be purged with a clean, dry and inert gas or a non-aggressive and non-corrosive solvent.

In case of severe contamination, cleaning of the inside of the instrument and of the valve orifice (if applicable) may be required.



Inexpertly servicing instruments can lead to serious personal injury and/or damage to the instrument or the system it is used in. Servicing must therefore be performed by trained and qualified personnel. Contact your Bronkhorst representative for information about cleaning and calibration. Bronkhorst has a trained staff available.

1.6 Documentation



The documentation listed in the following table is available on the **mini CORI-FLOW** product pages under www.bronkhorst.com/products

Type	Document name	Document no.
Brochures	mini CORI-FLOW Brochure	9.60.056
Manuals	Instruction Manual mini CORI-FLOW ML120 (this document)	9.17.097
	Quick Installation Guide mini CORI-FLOW	9.17.093
Technical documentation	Hook-up diagram Analog/RS232	9.16.132
	Hook-up EtherNet/IP	9.16.222
	Hook-up diagram CANopen	9.16.218
	Hook-up diagram DeviceNet™	9.16.135
	Hook-up diagram EtherCAT®	9.16.137
	Hook-up diagram FLOW-BUS	9.16.133
	Hook-up diagram Modbus ASCII / RTU	9.16.136
	Hook-up diagram Modbus TCP	9.16.235
	Hook-up diagram PROFIBUS DP	9.16.134
	Hook-up diagram PROFINET	9.16.146
	Hook-up diagram optional bus and I/O configurations	9.16.131
	Dimensional drawing	7.05.925



The documentation listed in the following table can be downloaded from www.bronkhorst.com/downloads

Type	Document	Document no.
General documentation	EU Declaration of Conformity	9.06.021
Manuals	Manual DeviceNet™ interface	9.17.026
	Manual EtherNet/IP interface	9.17.132
	Manual CANopen interface	9.17.131
	Manual EtherCAT® interface	9.17.063
	Manual FLOW-BUS interface	9.17.024
	Manual Modbus ASCII / RTU / TCP interface	9.17.035
	Manual PROFIBUS DP interface	9.17.025
	Manual PROFINET interface	9.17.095
	Manual RS232 interface	9.17.027

1.7 Model key

The model key on the serial number label contains information about the technical properties of the instrument as ordered. The specific properties can be retrieved with the diagram below.

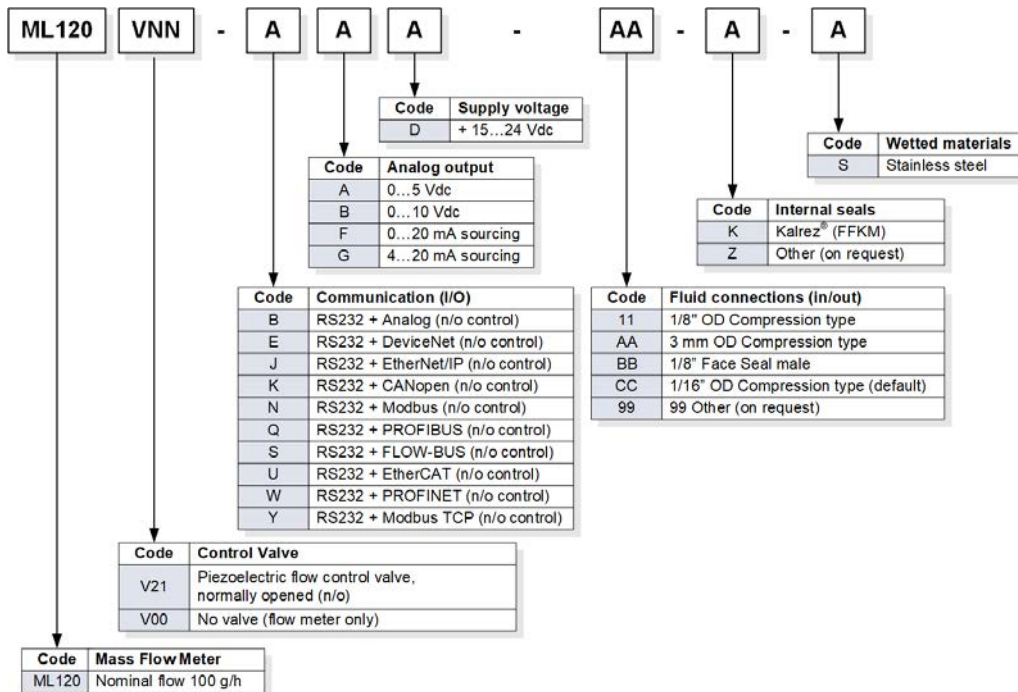

1.8 Customized I/O options

mini CORI-FLOW ML120 instruments offer several customized input/output functions through pin 5 of the M12 connector as an option. The required I/O options are factory installed as specified at ordering time, and cannot be changed manually.

The possible configurations are described in the table below. See the hook-up diagram for custom bus and I/O configurations (document 9.16.118) for an explanation of the codes.

Code	Description
000	Disabled, pin 5 is pulled down to 0 Vdc (default selection)
A1V	0...10 Vdc sourcing output, controller Analog signal for pump or external valve steering (control signal only). When the controller output is used for pump or external valve steering (only applicable to mass flow meters with the controller function enabled), make sure to set parameter <i>Valve maximum</i> to 0.3 [A]. For mass flow controllers, the controller output signal represents the valve actuator current. This output is limited to a value below 10 Vdc, due to the maximum valve current restriction.
B1V	4...20 mA sourcing output, controller Analog signal for pump or external valve steering (control signal only). When the controller output is used for pump or external valve steering (only applicable to mass flow meters with the controller function enabled), make sure to set parameter <i>Valve maximum</i> to 0.3 [A]. For mass flow controllers, the controller output signal represents the valve actuator current. This output is limited to a value below 20mA, due to the maximum valve current restriction.
C3A	Digital output, min/max alarm During a min/max alarm, pin 5 is pulled down to 0 Vdc.
C4A	Digital output, counter alarm During a counter alarm, pin 5 is pulled down to 0 Vdc.

Code	Description
C5S	<p>Digital output, enabled by setpoint (for shut-off control) Pin 5 is pulled down to 0 Vdc at a controller setpoint, e.g. for shut-off valve activation.</p> <p>For factory selected analog control (...-A#-C5S): If parameter <i>Control mode</i> is set for analog control by factory, the minimum setpoint at which the device (shut-off valve) connected to pin 5 is activated is 1.9%. This prevents possible noise on the analog input activating the device accidentally.</p> <p>For factory selected digital control (...-D#-C5S): If parameter <i>Control mode</i> is set for digital control by factory, the setpoint threshold for activating the device connected to pin 5 is any value > 0.</p> <p>Note: If the instrument is forced into Valve Safe State, the digital output is not affected, so a (n/c) shut-off valve connected to pin 5 will not close when the (n/c) controller is in Valve Safe State.</p> <p>Make sure to use 24 Vdc power supply corresponding to the shut-off valve specifications. Cable 7.03.572 (T-part 9-pin D-sub/loose end) or 7.03.603 (T-part 9-pin D-sub/DIN43650C) can be used for this operating option.</p>
C0I	<p>Digital output, high/low switch using remote parameter (e.g. for shut-off valve control) Pin 5 is pulled down to 0 Vdc when writing value 1 to parameter <i>IO switch status</i>, this is undone by writing value 0.</p> <p>A device connected to pin 5 (e.g. a shut-off valve) can be activated/deactivated by writing parameter <i>IO switch status</i>.</p> <p>Note: If the instrument is forced into Valve Safe State, the digital output is also affected, so a (n/c) shut-off valve connected to pin 5 will be closed when the (n/c) controller is in Valve Safe State.</p> <p>Make sure to use 24 Vdc power supply corresponding to the shut-off valve specifications. Cable 7.03.572 (T-part 9-pin D-sub/loose end) or 7.03.603 (T-part 9-pin D-sub/DIN43650C) can be used for this operating option.</p>
D9E	<p>Digital frequency output, measure Measurement value is translated to a frequency within given frequency range.</p> <p>The default frequency range to represent 0...100% flow is 0...10000 Hz. Any other frequency range must be specified on order.</p>
F9B	<p>Digital pulse output, batch counter Pin 5 is pulled down to 0 Vdc when a given batch size is reached (during a given pulse length).</p> <p>By default, a pulse is given at each 1x the <i>Counter unit</i> batch value, with a pulse length of 1 second. For instance, when <i>Counter unit</i> is set to 'ln', a pulse is given each time 1 ln has passed through the instrument. An alternative pulse length must be specified on order.</p> <p>Provide a pull-up resistor of 5...10 kOhm to create 15...24 Vdc at pin 5 (according to the applicable hook-up diagram).</p>
I3C	<p>Digital input, controller mode valve close Valve closes when pin 5 is connected to 0 Vdc.</p> <p>This option switches between the default <i>Control mode</i> and mode 'Valve Close' (value 3). When the default <i>Control mode</i> is digital, the default value is 0 (bus/RS-232), when the default <i>Control mode</i> is analog, the default value is 1 (Analog input).</p>

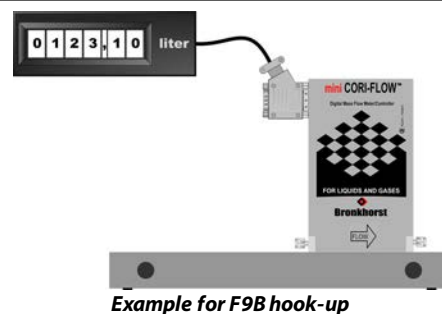
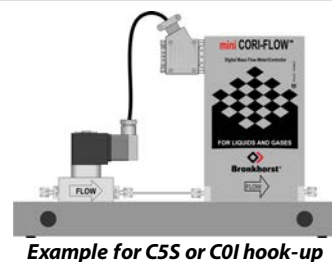

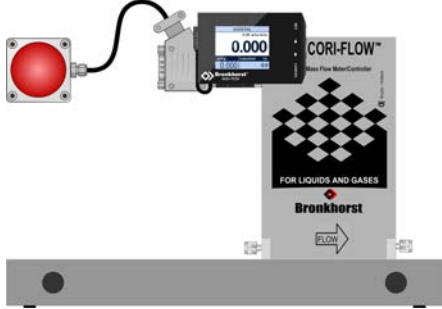
Code	Description
I8C	<p>Digital input, controller mode valve purge Valve is fully opened when pin 5 is connected to 0 Vdc.</p> <p>This option switches between the default <i>Control mode</i> and mode 'Valve Fully Open' (value 8). When the default <i>Control mode</i> is digital, the default value is 0 (bus/RS-232), when the default <i>Control mode</i> is analog, the default value is 1 (Analog input).</p>
I1R	<p>Digital input, reset counter The counter resets when pin 5 is connected to 0 Vdc.</p> <div style="text-align: right;">  <p>Example for I1R or I2R hook-up</p> </div>
I2R	<p>Digital input, reset alarm The alarm resets when pin 5 is connected to 0 Vdc.</p>

2 Starting up

2.1 Functional properties

Before installing your **mini CORI-FLOW ML120**, check the serial number label on the rear side of the instrument to see if the functional properties match your requirements:

- Flow rate
- Fluid to be measured
- Up- and downstream pressures
- Temperature
- Valve type (NO= Normally Open)
- Input/output signal (see also [Electrical connection](#))



The Lab-style instrument housing is rated at IP40.

2.2 Operating conditions

2.2.1 Tested pressure



mini CORI-FLOW instruments are pressure tested to at least 1.7 times the specified operating pressure, with a minimum of 340 bar(a) for meters and 8.5 bar(a) for controllers. Each instrument is also outboard leak tested to at least 2×10^{-9} mbar l/s Helium.

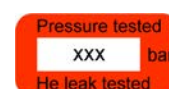

The tested pressure is specified on the instrument with a red sticker. If this sticker is missing or if the specified pressure is insufficient, the instrument must not be used and should be returned to the factory.

Before installation, make sure that the tested pressure is in accordance with the safety factor of your application. The tested pressure must always be higher than the maximum operating pressure.

Disassembling the instrument and/or replacing parts of it will invalidate the pressure test specification.

2.2.2 Sealing material



mini CORI-FLOW ML120 instruments are equipped with specific sealing material(s), compatible with the media specified at ordering time. Be sure that the sealing materials are compatible with the media and conditions used in the system. Do not exceed the indicated maximum operating pressure and temperature. Bronkhorst High-Tech B.V. cannot be held responsible for any damage resulting from the use of other media and/or conditions than specified at ordering time.

mini CORI-FLOW ML120V00 instruments are metal sealed.

mini CORI-FLOW ML120V21 instruments are equipped ex factory with internal sealings in the piezo-valve, compatible with the media specified at ordering time. As a factory standard, the instruments are provided with Kalrez® (FFKM) seals.

2.3 Piping requirements



MAKE SURE THAT THE PIPING IS ABSOLUTELY CLEAN!

Particles can damage or clog the instrument. The piezo valve's metal membrane can be seriously damaged by particles in the fluid.



During the manufacturing process, the instrument has been tested with water. Despite the fact that it has been purged thoroughly afterward, the instrument cannot be guaranteed to be absolutely free of water droplets upon delivery. For applications where remaining water particles might cause undesired reactions, such as corrosion, Bronkhorst strongly recommends performing an additional, adequate drying procedure.

2.4 Mounting

For the **mini CORI-FLOW ML120** proper stable mounting is strongly advised on a rigid, solid base for optimal accuracy. For optimal isolation from vibrations in the area, rubber suspension pads can be used.

The picture to the right shows an example of a **mini CORI-FLOW ML120** with a mass block, one of the options Bronkhorst can provide for isolation from vibrations in the environment where the instrument is used.

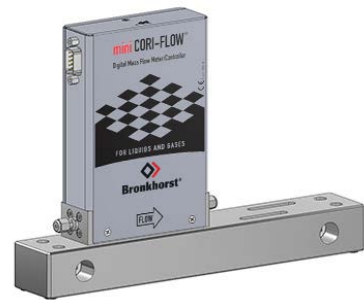

2.5 Leak check

Bronkhorst® **mini CORI-FLOW** meters/controllers are fitted with compression or face-seal-fittings.

For leak tight installation of compression type fittings make sure that the tube is inserted to the shoulder in the fitting body and that no dirt or dust is present on tube, ferrules or fittings. Tighten the nut finger-tight; while holding the instrument and then tighten the nut 1 turn.

If applicable follow the guidelines of the supplier of the fittings. Special types of fittings are available on request.



Check the fluid system for leaks before applying full operating pressure, especially when using hazardous media (e.g. toxic or flammable).



After using the mini CORI-FLOW for the first time with low temperature media, re-tighten the fluid connections, in order to prevent leakage.

2.6 Preventing hydraulic shocks



In a fluid system where fluid movement (liquid or gas) is forced to stop or start suddenly (by a pump or a shut-off valve), a hydraulic shock (or fluid hammer) can occur, especially if the fluid velocity is high. This momentum change causes a pressure surge (spike) traveling repeatedly from one end of the piping to the other. Rapid pressure fluctuations like this can cause leakage and damage to fluid lines and components, and ultimately damage to the instrument.

The following measures can be taken to prevent or minimize hydraulic shocks:

- Avoid abrupt fluid acceleration and deceleration
 - Avoid large pipe diameter transitions by using piping and tubing with an inside diameter that matches that of the instrument as closely as possible
 - Keep the fluid velocity through the instrument as small as possible
- Install an accumulator to dampen acceleration and deceleration of the fluid flow

Consult your Bronkhorst representative if you need more information about prevention of hydraulic shocks.

2.7 Electrical connection

Electrical connection must be made with standard cables or according to the applicable hook-up diagrams. The factory installed 9-pin D-sub settings are indicated on the serial number label. Make sure that the power supply is suitable for the power ratings as indicated on the serial number label and that double or reinforced insulation is used for the power supply.

Bronkhorst recommends using their standard cables. These cables have the right connectors and if loose ends are used, these are marked to prevent wrong connection.



mini CORI-FLOW ML120 instruments are powered with +15...+24 Vdc. See the hook-up and cabling examples in section [Communication interface](#)



Never power the instrument simultaneously from **two different power sources** (e.g. fieldbus and Plug-in Power Supply). Doing so will damage the printed circuit board irreparably.



The device described in this document contains electronic components that are susceptible to **electrostatic discharge**. In order to prevent damage, proper handling procedures must be followed during installation, (dis)connecting and removing the electronics.

The device carries the CE-mark and is **compliant with the concerning EMC requirements**. However, EMC requirements can only be met using appropriate cables and connector/gland assemblies. Bronkhorst recommends the use of their standard cables. These cables have the right connectors and loose ends (if any) are marked to help prevent wrong connection. When using other cables, cable wire diameters must be sufficient to carry the supply current, and voltage loss must be kept as low as possible. When in doubt, contact your Bronkhorst representative.

When connecting the product to other devices, be sure that the integrity of the shielding is not affected; **always use shielded cabling for signals and communication and do not use unshielded wire terminals**.

2.8 Communication interface

The table below shows the different (fieldbus) interfaces that can be installed. LED indications and the use of the micro switch button on top of the instrument are explained in [LED indications](#) and [Multifunctional switch](#) respectively.



An analog and (digital) RS232 interface are always available on mini CORI-FLOW ML120 instruments. A fieldbus interface is optional.

- The analog and RS232 interface are made available through a 9-pin D-sub connector on the side of the instrument
 - see [Analog or local interface](#) and [Digital RS232 interface](#)
- FLOW-BUS and Modbus communication is possible through the 9-pin D-sub side connector, as well as via an optional fieldbus connector on the top of the instrument
 - see [Digital RS485 interface](#)
- All other fieldbus interfaces are strictly made available through a connector on top of the instrument
 - see [Digital RS485 interface](#)

2.8.1 Analog or local interface

Connect the mini CORI-FLOW ML120 instrument to the power supply/readout unit using a cable with 9-pin D-sub connector according to the Bronkhorst® standard for the Sub-D9 connector.

Refer to the hook-up diagram for analog operation (document 9.16.119) or use a 9-pin D-sub loose-end cable (7.03.004 (3m), 7.03.536 (5m) or 7.03.537 (10m)) to connect the required signals.

Power	: +15...+24 Vdc
Analog output	: 0...5 Vdc / 0...10 Vdc 0...20 mA / 4...20 mA
Analog input (controller)	: 0...5 Vdc / 0...10 Vdc 0...20 mA / 4...20 mA

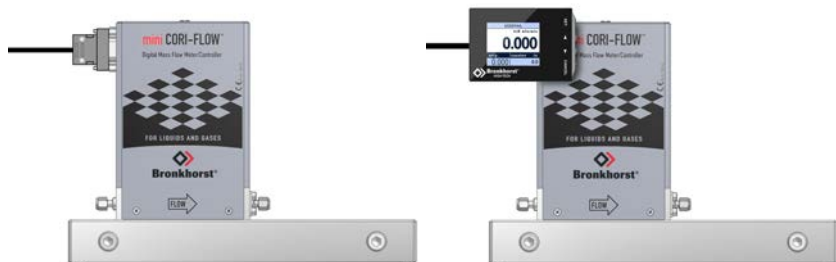

The following analog signals are available through the 9-pin D-sub side connector:

- Pin 2: measured value (analog output)
- Pin 3: setpoint (analog input)

The factory selected analog interface (0...5 Vdc; 0...10 Vdc; 0...20 mA or 4...20 mA) can be found in the model key of the instrument (see [Model key](#)) and in the pin description on the serial number label.



When operating the instrument through the analog interface it is possible to connect the instrument simultaneously to RS232 for reading/changing parameters (e.g. settings or fluid selection).

2.8.2 Digital RS232 interface

A special T-part cable (7.03.366) is required for connecting the 9-pin D-sub side connector of a **mini CORI-FLOW ML120** instrument to a COM port of a Windows computer for RS232 communication. Optionally use an RS232 to USB2.0 converter (9.09.122) to connect to a USB port. Use a Plug-in Power Supply (PiPS) (7.03.422) for powering the instrument.

Alternatively use a 9-pin D-sub loose-end cable and refer to the hook-up diagram for RS232 operation (document 9.16.119) to connect the required signals, typically for connection to a PLC or micro controller device.

If an instrument is powered through the (optional) bus connector on top of the instrument, the 9-pin D-sub side connector can be connected to a COM port directly, using a T-part cable 7.03.366 or an RS232 cable 7.03.367. The figure on the right shows a hook-up example for DeviceNet™.

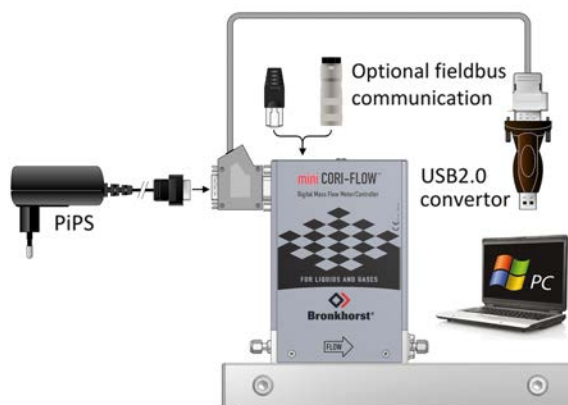

Keep in mind that the 9-pin D-sub configuration of a Bronkhorst® instrument differs from the 9-pin D-sub configuration of a PC COM-port. Make sure the correct cables are used for hook-up. When in doubt, always check the hook-up diagrams associated with the instruments.



- Consult **Instruction manual PiPS** (document no. 9.17.055) for more information about the Plug-in Power Supply
- Consult **Instruction manual RS232 interface** (document no. 9.17.027) for more information about hook-up and communication

Both documents can be downloaded from www.bronkhorst.com/downloads

2.8.2.1 E-8000

When a **mini CORI-FLOW ML120** instrument is used in combination with an E-8000 readout/ control unit equipped with an RS232 interface, the instrument can be powered and operated using the 9-pin D-sub (female) connector at the rear of the E-8000 module and a cable 7.03.016 or equivalent. With the display interface and control buttons most digital parameters can be used. See the E-8000 manual (document 9.17.076) for more information.

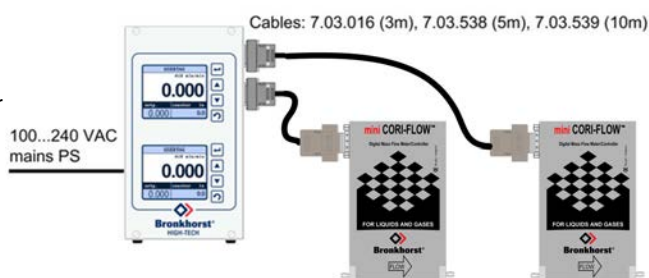

2.8.2.2 BRIGHT

When a **mini CORI-FLOW ML120** instrument is used in combination with a BRIGHT readout and control module, most digital functions are available by using the display interface and control buttons. If a BRIGHT module is connected, no other RS232 communication with the instrument can be established. For more information see the BRIGHT manual (document 9.17.048).



2.8.3 Digital RS485 interface

With digital operation over RS485 or Ethernet a fieldbus system with multiple instruments can be set up. This section shows examples of several of **mini CORI-FLOW ML120** instruments in an RS485 fieldbus system. Note that many other bus

configurations are possible, contact your local sales representative for more information. Please check the total power consumption of your instruments and do not exceed the maximum power of the power supply.

For all fieldbus systems the **mini CORI-FLOW ML120** instruments serve as slaves on the master/slave bus system. There is no mutual communication between slaves, only between master and slave.

2.8.3.1 FLOW-BUS

In the image below an E-8000 power supply/readout control unit with FLOW-BUS interface is connected to two **mini CORI-FLOW ML120** instruments via the RJ-45 top-connector FLOW-BUS interface. In this example one instrument serves as 'local host' for communicating with a Windows computer to all instruments on the bus via an available RS232 connector. Note: communication with all the instruments on the FLOW-BUS system is possible when using an **mini CORI-FLOW ML120** instrument as local-host RS232/FLOW-BUS interface. It is also possible to use multiple local-host RS232/FLOW-BUS interfaces in a FLOW-BUS system simultaneously.

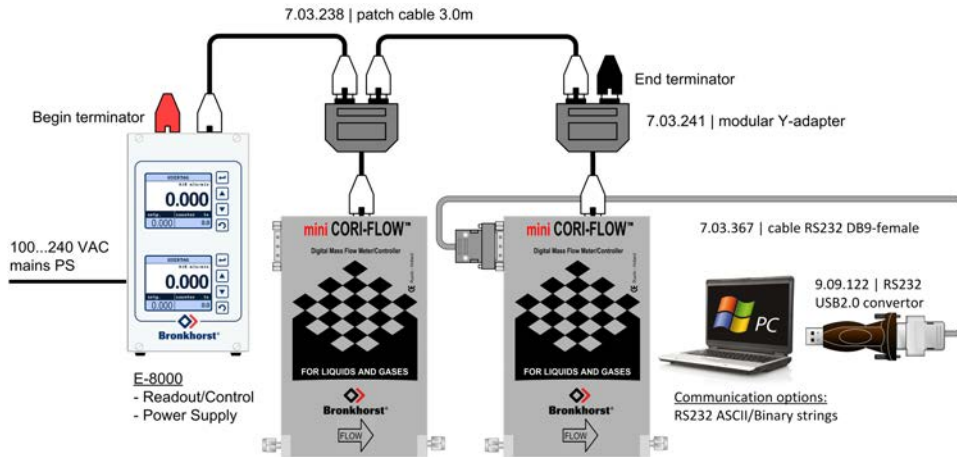

Power the instruments in a FLOW-BUS local-host system by hooking-up the power supply directly on the FLOW-BUS line and not by powering a set of instruments through the 9-pin D-sub connector on one of the digital instruments.



Consult **Instruction manual FLOW-BUS interface** (document no. 9.17.024) for more information about hook-up and communication.

2.8.3.2 Modbus

In the example below the Modbus power supply is provided by an E-8000. The instruments are connected to the bus via RS485 cables with RJ-45 connector and a Multiport connector. The RS485 - USB2.0 adapter can be used to connect the system to a Modbus master device.

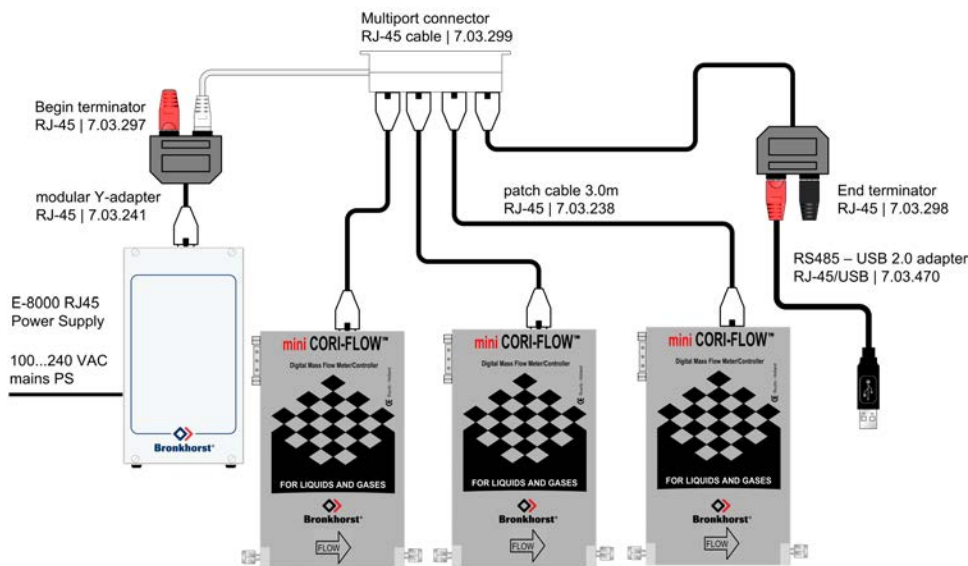



- See **Instruction manual Modbus interface** (document no. 9.17.035) for more information about hook-up and communication.
- See **Instruction manual E-8000** (document no. 9.17.076) for more information about power supply and communication options of the E-8000.

2.8.3.3 Other fieldbuses

PROFIBUS DP

PROFIBUS DP is a 2-wire, RS-485-based industrial data communication standard (fieldbus) which allows automation components (e.g. sensors, actuators and controllers) to exchange information.



Consult **Instruction manual PROFIBUS DP interface** (document no. 9.17.025) for more information about setting up a PROFIBUS DP network.

DeviceNet™

The DeviceNet™ interface offers a direct connection to a DeviceNet™ network, according to the mass flow controller profile specified by the ODVA. The Bronkhorst® DeviceNet™ instrument is a Group 2 Only Server device whose messages comply with the Controlled Area Network (CAN) 2.0A standard and with the DeviceNet™ protocol.



Consult **Instruction manual DeviceNet™ interface** (document no. 9.17.026) for more information about setting up a DeviceNet™ network.

EtherCAT®

Ethernet for Control Automation Technology (EtherCAT®) is an open high performance Ethernet based fieldbus system.



Consult **Instruction manual EtherCAT® interface** (document no. 9.17.063) for more information about setting up an EtherCAT® network.

PROFINET

The PROFINET interface is 100% Ethernet compatible and is used for data exchange between I/O controllers (PLC, etc.) and I/O devices (slaves, field devices). PROFINET uses the proven communication model and application view of PROFIBUS DP.



Consult **Instruction manual PROFINET interface** (document no. 9.17.095) for more information about setting up a PROFINET network.

2.9 Micro switch operation and LED indications

Using the two colored LEDs and the micro switch on the instrument, several actions can be monitored and started.

- The green ● LED is used for status indication.
- The red ● LED is used for errors, warnings and messages.
- The switch can be used to start several actions, such as auto-zero, restore factory settings and bus-initialization actions, if applicable.

For the zero-procedure see [Zeroing](#).

For an overview of all possible LED indications, see [LED indications](#).

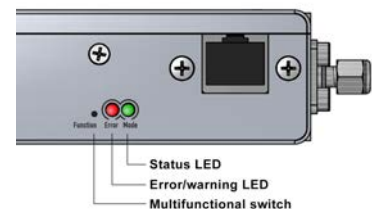

The micro switch on top of the **mini CORI-FLOW ML120** can be operated with a thin, metal or hard plastic pin, e.g. the end of a paperclip. Avoid excessive force when operating the switch.

2.10 Purging before use



In systems for use with corrosive, reactive or explosive media, purging for at least 30 minutes with a dry, inert gas (like Nitrogen or Argon) is absolutely necessary before use. After use with corrosive or reactive fluids, complete purging is also required before exposing the system to air.

Prevent chemical reactions inside the tubes or instrument as this will tend to clog up or corrode the system.

2.11 Zeroing

Zeroing of a **mini CORI-FLOW** instrument is required each time process conditions have been changed.

What is zero-stability?

Due to mechanical construction of the sensor tubes each **mini CORI-FLOW** sensor will have a very small offset signal, even when the mass flow is zero. This is called the zero-stability error and is specified for accuracy separately for all Coriolis instruments. Main reason for this is the fact that this error can be (temporarily) neutralized after performing a zero-action. Immediately after zeroing, zero-stability error is 0%. However, it is allowed to move between a certain band depending on the environment (process) and fluid conditions.

In ideal situations, where actual process conditions do not change, this error will remain the same. See below for possible reasons of change of zero-stability.

Model*	DN (mm)	Zero-stability	Nominal flow
ML120	0.25	< 0.01 g/h	100 g/h

*Zero-stability depends on the (mini) CORI-FLOW model



In practice zero-stability turns out to be better than the values in the table, but for calculation we will take worst case values.

Process conditions

Each time process conditions have been changed significantly a (mini) CORI-FLOW needs to be zeroed in order to get rid of the offset error due to zero-stability. At least the very first time an instrument is used a zero procedure will be required.

The zero-stability error will mainly change when one or more of the following items change significantly:

- Temperature (of fluid or environment)
- Mounting of the (mini) CORI-FLOW instrument

Less important items:

- Pressure
- Density of fluid
- Vibrations working on instrument via environment
- Pulsation of supply pressure working on instrument

Zero Procedure

There are two ways to perform zeroing of a (mini) CORI-FLOW instrument:

1. With the micro-switch
2. Through digital communication



Always make sure that there is absolutely no flow when the instrument is performing the (auto-)zero procedure and there are no mechanical vibrations or pulsating inlet pressures.

If the instrument has problems finding a proper and stable zero, it will repeat the auto-zero procedure up to 4 times. Each time when no proper zero can be achieved, the instrument will give a short notice, signaling its LEDs after the procedure. The red and green LED will blink alternating for a few seconds to indicate that the auto-zero was not able to find a zero point (because of too much noise in the signal). This is mostly the case when the instrument is placed in a vibrating environment. When ready zeroing after trying max. 4 times, the final result for the zero value will be a moving average value of all attempts. The instrument will save this zero value into its non-volatile memory and will keep this value until the next zero-procedure is performed. The mini CORI-FLOW will accept a proper zero point only if the measured signal is within a limited noise band. Best way to achieve this is to avoid external noise influences. However, when this is not possible, filter settings of the mini CORI-FLOW can be changed to improve noise immunity.

2.11.1 Zeroing using micro switch



The zero-point of each instrument is factory adjusted. If so required the zero point may be re-adjusted over RS232, fieldbus or by means of using the micro switch.

Procedure for zeroing by micro switch:

1. Set process conditions

Warm-up (for a minimum of 30 minutes), pressurize the system and fill the instrument according to the process conditions.

2. Stop flow

Make sure no flow is going through the instrument by closing valves near the instrument. The setpoint must be zero.

3. Press and hold, until the GREEN LED is on, then release button

Press the micro switch and hold it. After a short time the red ● LED will go ON and OFF, then the green ● LED will go ON. At that moment (which is 8...12 s after pressing) release the switch.

4. Zeroing

The zeroing procedure will start at that moment and the green ● LED will blink fast. The procedure will take approximately 60 seconds.

5. Ready

When the indication is showing 0% signal and the green ● indication LED is glowing continuously again, the zeroing action was successful.

2.11.2 Zeroing through digital communication

It is also possible to start the zero adjustment procedure through digital communication:

- Through FLOW-BUS, using an E-8000 readout/control module
- Through FLOW-BUS, via a RS232/FLOW-BUS converter using software on a PC or PLC
- Through RS232, using software on a Windows computer or a PLC
- Through RS232, using a BRIGHT compact local readout/control module
- Through other fieldbus system (PROFIBUS DP/DeviceNet™/Modbus)

1. Set process conditions

Warm up and pressurize the system and fill the instrument according to the process conditions.

2. Stop flow

Make sure there is no flow through the instrument by closing the shut-off valves before and after the instrument.

3. Send parameters

Send the following parameter values in this sequence:

- Init Reset: 64
- Control Mode: 9
- Calibration Mode: 255
- Calibration Mode: 0
- Calibration Mode: 9

4. Zeroing

The zeroing procedure will start at that moment and the green LED will blink fast. The zeroing procedure waits for a stable signal and saves the zero. If the signal is not stable zeroing, it will take a long time and the nearest point to zero is accepted. The procedure will take approximately 60 seconds.

Make sure there is no flow through the instrument when performing the zeroing procedure.

5. Ready

When indication is showing 0% signal and the green indication LED is glowing continuously again, then zeroing has succeeded. Parameter *Control Mode* reverts to its original value. As last send 0 to parameter *Init Reset*.

2.12 Powering up and powering down

- *It is recommended to turn on power before applying fluid pressure and to switch off power only after relieving fluid pressure.*
- *For best performance, allow the device to warm up and stabilize for at least 30 minutes before starting measurement and/or control. This may be done with or without media flow.*



When applying pressure, avoid pressure shocks and bring the fluid system gradually up to the level of the specified operating conditions; open the fluid supply gently.



Make sure (in case of a controller) that the used control valve can withstand the system pressure and the maximum delta pressure allowed.

3 Operation

3.1 Mass flow measurement and control

After correct installation of the **mini CORI-FLOW ML120** Mass Flow Meter (MFM) or Mass Flow Controller (MFC), and when all safety precautions have been taken into account, the instrument can be used for measuring/ controlling the required flow rate in the system by means of the selected communication interface(s).

When an MFC (either with normally closed (N.C.) or normally open (N.O.) valve) is hooked-up, the control valve stays closed as long as no setpoint is given. When the MFC receives a setpoint from the active setpoint source, the internal controller will immediately open the control valve until the required flow rate is achieved. It will maintain that flow rate until another setpoint is given.

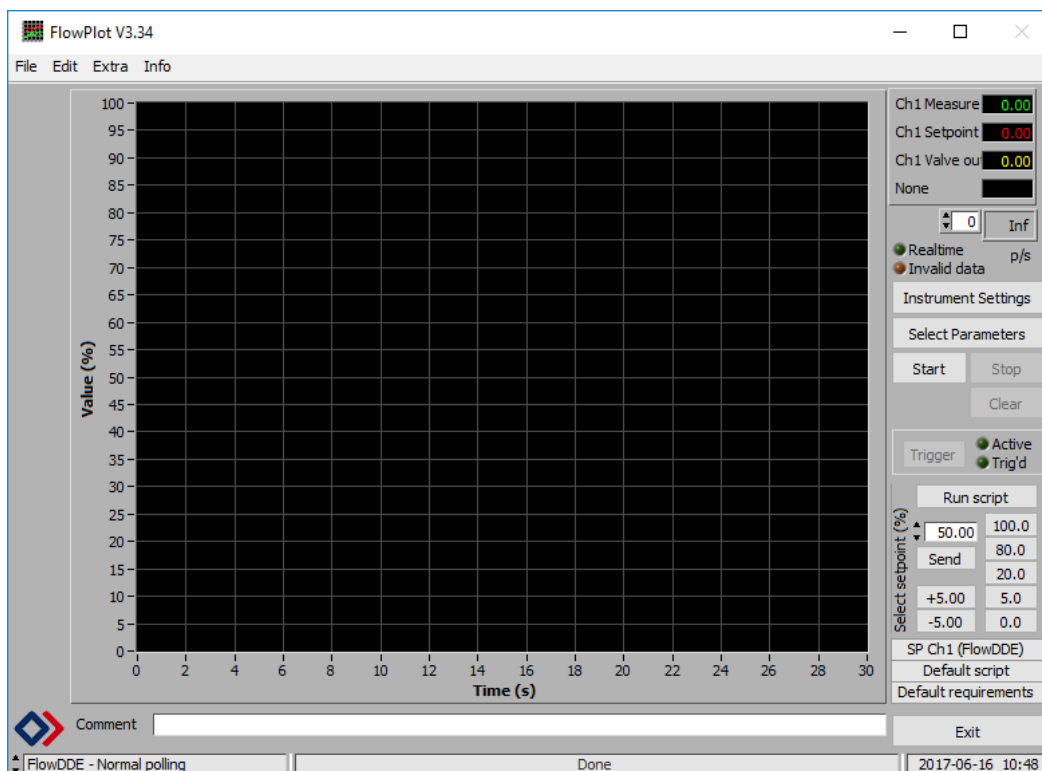

mini CORI-FLOW ML120 instruments are most accurate with the specified media, at the specified inlet/outlet pressure and temperature, as specified by the customer at ordering time. However, the instrument will function properly in a wide range of varying conditions. If the actual process conditions differ significantly from the conditions for which the instrument is set, the FlowTune™ software can be used to set the correct process conditions.

Although mini CORI-FLOW ML120 instruments have excellent temperature stability, the best accuracy is achieved when temperature gradients across the instruments are avoided. Make sure that the media temperature matches the ambient temperature as good as possible and mount the instruments on a rigid (heat conducting) surface.

mini CORI-FLOW ML120 instruments handle pressure shocks in the system well, but are not insensitive to pressure fluctuations. For optimum control stability, provide a stable (pressure controlled) inlet pressure with sufficient buffer volume between the pressure regulator and the instrument and avoid installing multiple instruments or control valves in close proximity to another with small volume piping in between.

3.1.1 Instrument settings

This window allows the user to read and change several settings of digital meters and controllers. Changing these parameters requires special knowledge about the instruments and the behavior of the instruments. This document may not be enough to optimize an instrument. Bronkhorst offers special trainings for field users for this. Please ask your local representative about this. From the moment the window appears, it will take a few seconds to read all the actual parameter values and update the screen. After that, changing a setting will immediately send the change to the instrument and the effect of the change can be viewed in the plot window.



Channel & control mode

- 0 – Bus/RS232** : Digital setpoint via fieldbus or RS232
- 1 – Analog input** : Setpoint via analog input
- 3 – Valve fully closed** : Valve fully closed and stays closed under all circumstances
- 8 – Valve fully open** : Valve fully opened (purge) and stays opened under all circumstances
- 11 – Keyboard & FLOW-BUS**: Setpoint via E-8000 keyboard, bus or RS232

Capacity and unit

- Unit type: Selects the flow measurement
- Mass flow
- Volume flow
- Full scale value: Selection of the Full scale

Sensor zero

Auto zero: adjustment of zero point

Notes: Instrument must be warmed up, no flow may flow during auto zero

3.1.2 Valve safe state

When a controlling instrument is not powered or cannot communicate with the fieldbus network (if applicable), the control valve automatically returns to its default state (also called Safe State), which is closed for a 'normally closed' valve (n/c) and fully open for a 'normally open' valve (n/o). Taking into account the typical process conditions under which the instrument is used (such as the processed media and ambient conditions; see also [Intended use](#)), the default state is generally considered safe.

Check the serial number label or the technical specifications to see which valve type is used on your instrument (if applicable).

3.2 Temperature considerations

Although the mini CORI-FLOW has excellent temperature stability, the best accuracy is achieved when temperature gradients within and across the instrument are avoided. Take the following guidelines into account:



- To avoid simultaneous heating and cooling of different parts of the instrument, make sure the ambient temperature is as stable and evenly distributed across the environment as possible.
- Avoid temperature shocks; heating or cooling should amount to no more than 1 °C per second.
- Make sure that the media temperature matches the ambient temperature as closely as possible.
- The mini CORI-FLOW will show an amount of self heating, due to power dissipation of the electronics. This effect can be as large as approximately 15 °C (depending on media and ambient temperature). In practice, there will be a balance between media temperature, self heating and ambient temperature.
- Operation in a cool environment can compensate somewhat for the effect of high media temperatures.
- Heating and cooling effects will also depend on the cooling/heat conducting capacities of the installation itself on which the instrument is mounted.



- To prevent damage to the electronics, make sure the temperature in the housing never exceeds 70°C. To monitor this, the internal temperature reading can be used (parameter [Temperature](#)).
- The storage temperature should lie between -30 and 80 °C. Make sure the measuring tube is purged and dry before storing the instrument.

Temperature build-up

The temperature in the instrument housing is largely determined by the media temperature (T fluid) and the ambient temperature (T ambient). Although these temperatures cannot simply be added up to calculate the internal temperature, they do amplify each other. Taking the self heating effect of the electronics into account, some rules of thumb can be defined for the maximum temperatures and their sum to observe. The graph below illustrates these; the area below each line represents the safe temperatures for the according instruments or circumstances.

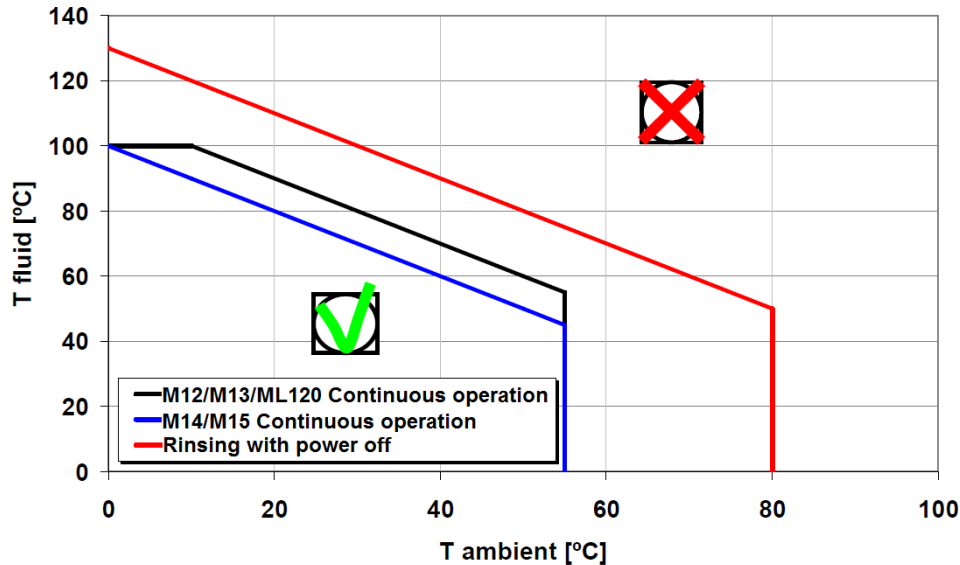

The following rules can be inferred from this graph:

With normal, continuous operation:

- T fluid + T ambient should remain lower than 110 °C
- T fluid should lie between 0 and 100 °C
- T ambient should lie between 0 and 55 °C

When cleaning (without electrical power to the instrument):

- T fluid + T ambient should remain lower than 130°C
- T fluid should lie between 0 and 130 °C
- T ambient should lie between 0 and 80 °C

3.3 Analog operation

With analog operation the following parameters are available:

- output signal: measured value
- input signal: setpoint (controller only)



Using analog and digital interfaces simultaneously

The instrument can be operated via the analog and digital interfaces (RS232/fieldbus) at the same time. When using multiple interfaces, reading of parameters can be done simultaneously. When changing parameter values, the last value sent by any of the interfaces will be valid.

Control mode

The instrument accepts a setpoint from either the analog or digital interface, but not both. This default control mode is selected at ordering time.

3.4 Basic RS232 operation

Connecting the instrument with an RS232 cable or an RS232 cable with a USB to RS232 converter to a Windows computer enables using the free Bronkhorst® software for Windows, such as FlowDDE and FlowPlot.

Digital operation via RS-232 or fieldbus (RS-485) adds extra features to the instrument, such as:

- Direct reading with a readout/control module or host computer
- Diagnostics
- Multi-fluid functionality (up to 8 fluids, if ordered; see [Fluid set](#))
- [Device identification](#)
- Adjustable minimum and maximum alarm limits ([Alarms](#))
- (Batch) counter ([Counter](#))



Make sure in FlowDDE the correct port and baud rate are selected. For RS232 operation the baud rate must be 38400 Baud.

3.4.1 FlowDDE

Digital Bronkhorst® instruments can be operated via RS-232 using the Bronkhorst® FlowDDE server application. Dynamic Data Exchange (DDE) provides a basic level of inter process communication between Windows applications. Together with a client application, either self-made or with a third party SCADA program, it is possible to create an easy way of data exchange between the flow meter/controller and a Windows application. For instance, a cell in a Microsoft Excel spreadsheet can be linked to the measured value of an instrument; FlowDDE updates the cell automatically when the measured value changes.

FlowDDE uses specific parameter numbers for communicating with the instrument. A DDE parameter number is a unique number in a special FlowDDE instruments/parameter database and not the same as the parameter number from the process on an instrument. FlowDDE translates the node-address and process number to a channel number.

DDE-client applications communicate with the FlowDDE server by using DDE messages. Before messages can be exchanged, a DDE link has to be made. A DDE link consists of three parts: the server, the topic and an item. For separation the characters '|' and '!' may be used, so a DDE link in e.g. Microsoft Excel becomes: Server|Topic|Item.

For standard instrument parameters and the FlowDDE server, these are:

- Server: FlowDDE or FlowDDE2
- Topic: 'C(X)' for channel number X
- Item: 'P(Y)' for parameter number Y

An example of a DDE link in a Microsoft Excel cell is =FlowDDE|C(1)!P(8) to read parameter 8 of channel 1.

When not using FlowDDE for communication with the instrument, parameters are addressed by:

- Node address of the instrument
- Process number on the instrument
- Parameter number on the instrument

See section [Digital parameters](#) for more information about instrument parameters.

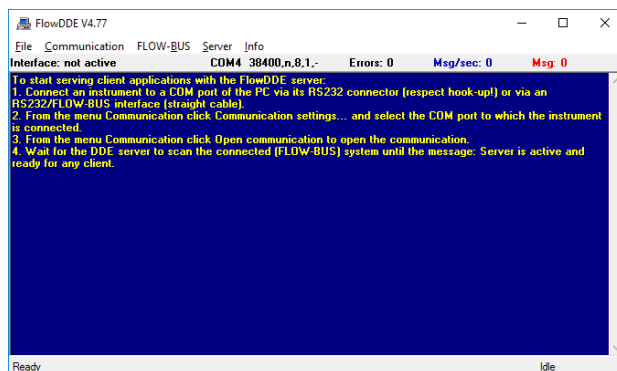

For more information about FlowDDE, including setting up a DDE link, consult the **FlowDDE Manual** (document no. 9.17.067) or the help file in the application.

3.4.2 Software (DDE applications)

Examples of free Bronkhorst® DDE client applications: FlowPlot and FlowView. Other software programs (third party) supporting DDE are for example MS-Office, LabVIEW, InTouch and Wizcon.

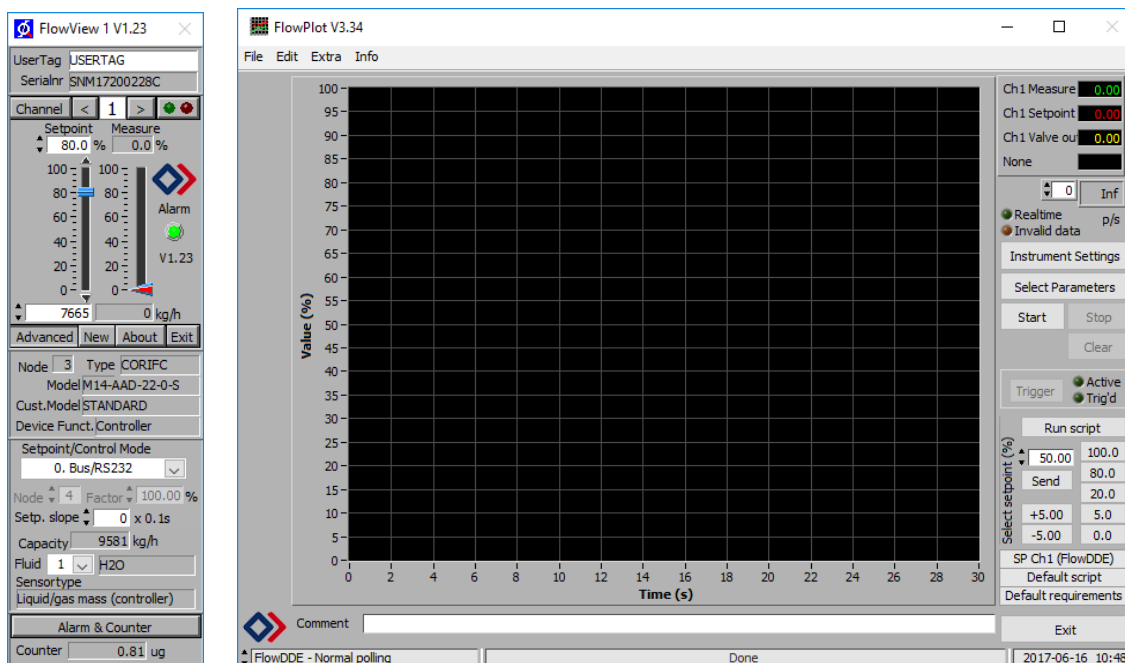

Bronkhorst® software applications 'FlowView' (left) and 'FlowPlot' (right)



FlowDDE and other Bronkhorst® applications are available on the support CD or can be downloaded from the product pages on the Bronkhorst website: www.bronkhorst.com/products

3.4.3 Baud rate, node address and parity

mini CORI-FLOW ML120 instruments support the following baud rates for RS232 communication. The factory selected baud rate is indicated on the serial number label. Refer to [Digital parameters - Network configuration](#) for changing the baud rate settings for the instrument. The default baud rate for RS232 communication is 38400 Baud.

Interface/medium:	RS232
Protocol:	FLOW-BUS
Baud rate:	9600 16200 38400 57600 115200 230400 460800
Node address:	3
Parity:	None



Make sure that the instrument's baud rate corresponds with the baud rate of the application the instrument is communicating with, otherwise no communication can be established.

For RS232 communication, the maximum cable length is 10 m for baud rates up to 38400 Baud. For higher baud rates, use cable lengths of maximum 3 m.



Changes made to the network settings will **not** be restored by a factory reset.



Consult **Instruction manual RS232 interface** (document no. 9.17.027) for more information about RS232 communication

3.5 Basic RS485 operation (FLOW-BUS/Modbus)

FLOW-BUS or Modbus communication is available if either a FLOW-BUS or Modbus (RJ-45) connector on top of the instrument is present, or if the 9-pin D-sub side connector is set for FLOW-BUS or Modbus communication.

3.5.1 FLOW-BUS

FLOW-BUS is a Bronkhorst® designed fieldbus, based on RS485 technology, for digital communication between devices, offering the possibility of host-control by a Windows computer.

Characteristics:

- Baud rates of 187500 (default) or 400000 Baud
- +15...24 Vdc supply voltage
- Easy installation and communication with other Bronkhorst® devices
- Automatic node search and bus optimization (gap fixing)
- PC communication via (local host) FLOW-BUS – RS232 interface
- Connection of max. 120 instruments on a single bus
- Maximum bus length: 600 m



Consult **Instruction manual FLOW-BUS interface** (document no. 9.17.024) for more information about FLOW-BUS communication.

3.5.2 Modbus

Modbus is a 3-wire, RS485-based fieldbus communication system for parameter value exchange. In this system each instrument/device is equipped with a micro controller for its own dedicated task but also for exchanging parameter value information with other devices connected to the same Modbus system. In a Modbus system Bronkhorst® instruments always serve as Modbus slaves. There is no mutual communication between Modbus slaves, only between master and slave. The master device is for example a Windows computer.

Characteristics:

- Several selectable baud rates between 9600 and 256000 Baud (default: 19200 Baud)
- +15...24 Vdc supply voltage
- connection of max. 247 instruments on a single bus
- supports RTU and ASCII protocols



Consult **Instruction manual Modbus interface** (document no. 9.17.035) for more information about Modbus communication.

Detailed information about Modbus can be found at **www.modbus.org** or the website of the Modbus organization in your country (if available).

3.5.3 Software

When using a Windows computer to communicate with **mini CORI-FLOW ML120** instruments only the FLOW-BUS protocol is supported by Bronkhorst® software. When using Modbus operation, software from third parties, such as LabVIEW, ModScan or a Modbus PLC must be used to serve as Modbus master.



An instrument with 9-pin D-sub side connector set for RS485 FLOW-BUS or Modbus communication will not respond when connecting to an RS232 configuration. If the instrument is not set for RS232 communication, use the micro switch on top of the instrument to overrule the custom settings and switch to RS232 communication settings: press and hold the micro switch at power-up and wait (12...16 sec) until both green and red LEDs flash (0.2 sec on, 0.2 sec off). Release the switch to activate the 'Configuration Mode'. In the 'Configuration Mode' the bus type and baud rate for the 9-pin D-sub side connector are set to RS232 FLOW-BUS (ProPar) at 38400 Baud. The 'Configuration Mode' remains active after power down. Use the same procedure to deactivate the 'Configuration Mode'.

3.5.4 Baud rate, node address and parity

mini CORI-FLOW ML120 instruments are configured ex factory. If there is a need of changing any of the specified RS485 settings, see the tables below for the supported configurations. The default selections are printed in boldface.

Interface/medium:	RS485		
Protocol:	FLOW-BUS	Modbus RTU	Modbus ASCII
Baud rate:	187500 400000	9600 19200 38400 56000 57600 115200 128000 256000	9600 19200 38400 56000 57600 115200 128000 256000
Node address:	3...125	1...247	1...247
Parity:	None	None; Even ; Odd	None; Even ; Odd

Changing RS485 settings of the RJ-45 top connector interface

In case the FLOW-BUS or Modbus RJ-45 fieldbus connector is used for bus communication, the node address can be easily set by using the rotary switches on the side of the instrument. Use the 'MSD' (Most Significant Digit) to set the 'tens' of the bus-address and the 'LSD' (least Significant Digit) to set the 'unit' of the bus-address (the example on the right reads '63'). Set the rotary switches to '00' for automatic installation. Refer to the corresponding fieldbus manual, **document 9.17.024** (FLOW-BUS) or document 9.17.035 (Modbus) for more details.

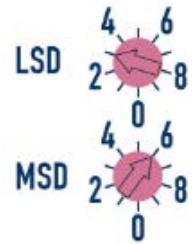

For changing the baud rate or parity settings use the RS232 interface to change the corresponding parameters. See [Digital parameters - Network configuration](#) for changing parameters.

Changing RS485 settings of the 9-pin D-sub side connector interface

In case the 9-pin D-sub side connector is set for RS485 communication, the baud rate or node address can be changed by using the micro switch or by changing the settings in the 'Configuration Mode'. Refer to section [Multifunctional switch](#) for changing node address and baud rate with the micro switch.

Other communication parameters can be changed only in configuration mode. See [Multifunctional switch](#) for entering configuration mode. In configuration mode, bus type and baud rate are set to RS232 (FLOW-BUS/ProPar) and 38400 baud respectively. Change the appropriate parameters as described in [Digital parameters - Network configuration](#). When finished, deactivate configuration mode using the same procedure.



Changes made to the network settings will **not** be restored by a factory reset.

3.6 Other fieldbus configurations

In the table below for the supported configurations for PROFIBUS DP, DeviceNet™, EtherCAT® and PROFINET are shown. The default selections are printed in boldface.

Connector:	9-pin D-sub (female)	5-pin M12 (male)	2x RJ45 (in/out)	2x RJ45
Interface/medium:	RS485	RS485	Ethernet	Ethernet
Protocol:	PROFIBUS DP	DeviceNet™	EtherCAT®	PROFINET
Baud rate:	Autodetect (9600) (19200) (45450) (93750) (187500) (500000) (1500000) (3000000) (6000000) (12000000)	125000 250000 500000	100000000	100000000
Node address:	0... 126	0.. 63	0 (n/a)	0 (n/a)
Parity:	Even	None	None	None

Changing PROFIBUS DP node address

The node address can be easily set by using the rotary switches on the side of the instrument. Use the 'MSD' (Most Significant Digit) to set the 'tens' of the bus-address and the 'LSD' (least Significant Digit) to set the 'unit' of the bus-address.

Changing DeviceNet™ node address and data rate

The node address and data rate can be easily set by using the rotary switches on the side of the instrument. Use the 'MSD' (Most Significant Digit) to set the 'tens' of the bus-address and the 'LSD' (least Significant Digit) to set the 'unit' of the bus-address. Set the 'MSD' rotary switch to 'P' to select programmable bus-address. For the data rate setting select '1' for 125000 Baud, '2' for 250000 Baud, '5' for 500000 Baud and 'P' for programmable data rate.

Changing EtherCAT® Second Address

EtherCAT® supports the use of a Second Address. Bronkhorst® instruments have 3 rotary switches, with which a Second Address can be set in the range of 0 – 4095 (0xFFF). This value of the rotary switches will be copied to the Configured Station Alias register (address 0x0012:0x0013) at instrument start-up.



Changes made to the network settings will **not** be restored by a factory reset.

3.7 LED indications

The following LED indicators are present on top of the instrument:

- **'Mode'** LED: green ● used for operation mode indication
- **'Error'** LED: red ● used for error/warning messages
- **'NET'** LED: green/red ●/● used for Network status (*DeviceNet™ only*)
- **'MOD'** LED: green/red ●/● used for Module status (*DeviceNet™ only*)
- **'Status'** LED: green/red ●/● used for status indication (*EtherCAT® and PROFINET only*)

For EtherCAT® and PROFINET the following LED indicators are integrated in the RJ-45 connectors:

- Amber LED: Ethernet Speed indicator
- Green LED: Ethernet Link/Activity indicator

The tables below list the possible indications by the LEDs on top of the instrument:

● Green		
Pattern	Time	Indication
off	Continuous	Power-off or program not running
on	Continuous	Normal Operation Mode
short flash	0.1 sec on, 2 sec off	No bus communication, valves are in safe state (PROFIBUS DP, DeviceNet™, EtherCAT® and PROFINET only). This LED indication is also active when the instrument is in 'Initialization Mode' (Init Reset = '73')
normal flash	0.2 sec on, 0.2 sec off	Special function mode; the instrument is busy performing a special function (e.g. auto-zero or self-test)
long flash	2 sec on, 0.1 sec off	Configuration mode; the baud rate and bus type for the 9-pin D-sub side connector are set to 38400 and RS232 FLOW-BUS (ProPar)

● Red		
Pattern	Time	Indication
off	Continuous	No error
on	Continuous	Critical error; the instrument needs servicing before it can be used
short flash	0.1 sec on, 2 sec off	Fieldbus specific warning message:

● Red		
Pattern	Time	Indication
		FLOW-BUS Node occupied: re-install instrument PROFIBUS DP No data exchange between master and slave (automatic recovery) Modbus Data is being received or transmitted DeviceNet™ Minor communication error EtherCAT® Instrument is not in OP mode PROFINET No application relation established
normal flash	0.2 sec on, 0.2 sec off	Incorrect fluid set configuration (see Digital parameters - Fluid set ; in this case valves are in safe state) AND/OR: Fieldbus specific warning message: FLOW-BUS Waiting for communication, check communication settings of all FLOW-BUS devices in the fieldbus setup. Usually the 'last node address' setting of one of the devices is incorrect. PROFIBUS DP Not used Modbus Not used DeviceNet™ No bus power EtherCAT® Not used PROFINET Not used
long flash	2 sec on, 0.1 sec off	Fieldbus specific warning message: FLOW-BUS Not used PROFIBUS DP Requested parameter not available Modbus Not used DeviceNet™ Serious communication error; manual intervention needed EtherCAT® Configuration error PROFINET Configuration error (e.g. a requested parameter is not available)

● Green and ● red (alternating)		
Wink	Time	Indication
slow wink	1 sec on, 1 sec off	Alarm indication; minimum/maximum alarm, power-up alarm, limit reached or batch reached
normal wink	0.2 sec on, 0.2 sec off	Wink mode; by sending a command to the <i>Wink</i> parameter, the instrument flashes its LEDs to indicate its position in a (large) system.
fast wink	0.1 sec on, 0.1 sec off	Selected action started (after releasing the multifunctional switch)

DeviceNet™ LED indications

Specific LED indications are applicable to instruments with DeviceNet™ interface. Note: the 'NET' and 'MOD' LEDs are bi-colored LEDs (green/red). Refer to the DeviceNet™ manual, **document 9.17.026**, for more information.

EtherCAT® LED indications

Specific LED indications are applicable to instruments with EtherCAT® interface. Refer to the EtherCAT® manual, **document 9.17.063**, for more information.

PROFINET LED indications

Specific LED indications are applicable to instruments with PROFINET interface. Refer to the PROFINET manual, **document 9.17.095**, for more information.

3.8 Multifunctional switch





The micro switch on top of the **mini CORI-FLOW ML120** can be operated with a thin, metal or hard plastic pin, for example the end of a paperclip.

Some special functions of the instrument can be started manually using the multifunctional switch near the indication LEDs. These functions are available in analog as well as in digital operation mode.

3.8.1 Normal operating functions

- In order to access these functions, press and hold the switch while the instrument is in normal operation mode (green LED glowing).
- As long as the switch is held, the LEDs show a repeating sequence of patterns, where each pattern indicates a function.
- All indications in this sequence are continuous.
- Each pattern is shown for a number of seconds; in the table below the column *Hold time* indicates the time frame within the sequence where the LEDs show the associated pattern.
- To start a function, release the switch when the LEDs show the pattern of the required function.



 (green)	 (red)	Hold time	Function
off	off	0...1 sec	No action
off	off	1...4 sec	1. In case of a min/max alarm: reset alarm 2. FLOW-BUS: Auto-install to bus - lets instrument obtain free node address if configured node address is occupied Note: min/max alarm (if any) has to be reset before auto install can be performed.
off	on	4...8 sec	Reset instrument; clear all warnings and error messages and restart the instrument
on	off	8...12 sec	Auto-zero; re-adjust the zero-point of the instrument (flow meters/controllers only)
on	on	12...16 sec	Enable FLASH mode for firmware update: <ul style="list-style-type: none"> • the instrument shuts down and both LEDs are switched off • at the next power-up, the instrument will be active again



See [Zeroing](#) for background information and instructions on how to adjust the zero point of an instrument.
Never perform a zeroing procedure before having taken notice of the instructions.

3.8.2 Power-up functions





- In order to access these functions, press and hold the switch while powering up the instrument.
- As long as the switch is held, the LEDs show a repeating sequence of patterns, where each pattern indicates a function.
- All indications in this sequence are flashing (0.2 sec on, 0.2 sec off).
- Each pattern is shown for a number of seconds; in the table below the column *Hold time* indicates the time frame within the sequence where the LEDs show the associated pattern.
- To start a function, release the switch when the LEDs show the pattern of the required function.

 (green)	 (red)	Hold time	Function
off	off	0...4 sec	No action
off	on	4...8 sec	Restore factory settings (except communication settings)
on	off	8...12 sec	FLOW-BUS Auto install to bus; let the instrument obtain a free node address from the FLOW-BUS system Other protocols No action
on	on	12...16 sec	Activate configuration mode <ul style="list-style-type: none"> • The 9-pin D-sub connector is set to RS-232 communication (ProPar) at baud rate 38400 • In configuration mode, the green LED blinks (2 seconds on, 0.1 second off) • Configuration mode remains active after powering-down and can be deactivated by selecting this function again at the next start-up

3.8.3 Control mode - readout/change

Reading control mode

- By briefly pressing the switch 2 times with intervals of up to 1 second in normal operation mode, the instrument shows its current control mode with a series of consecutive LED indication patterns.
- The number of flashes corresponds to the current value of parameter *Control Mode* (see [Special parameters](#)).





Step	Pattern	Indication
1.	Green  	number of flashes indicates the tens of the parameter value
2.	Red  	number of flashes indicates the units of the parameter value

Examples:

- for value 1 (control mode 'Analog input'), the green LED will flash 0 times and the red LED 1 time
- for value 22 (control mode 'Valve Safe State'), the green and red LED will each flash 2 times

Changing control mode

- By briefly pressing the switch 4 times with intervals of up to 1 second in normal operation mode, the instrument enters a state in which the control mode can be changed.
- This is done in 2 steps, each represented by a LED indication pattern (green or red; see table below).
- The number of flashes corresponds to the available values of parameter *Control Mode* (see [Special parameters](#)).
- At the start of each step, the according LEDs starts flashing fast (0.1 second on, 0.1 second off). By pressing and holding the switch, the associated action is started and the flashing slows (0.5 seconds on, 0.5 seconds off).

Step	Pattern	Maximum flash count	Action
1.	Green  	2	set tens of parameter value
2.	Red  	9	set units of parameter value

To execute a step, follow these instructions:

- Press and hold the switch (flashing slows)
- To select value 0 (zero), release the switch within 1 second, otherwise:
- Count the number of LED flashes
- Release the switch when the required value is reached
- In case you lose count, keep the switch pressed and wait until the flash count reaches its maximum and restarts

On completion of step 1, the instrument automatically advances to step 2. When both steps have been completed, the instrument returns to its normal operation mode.

If the switch is not pressed within 60 seconds after starting a step, all changes are canceled and the instrument returns to its normal operation mode.









Note that this procedure also sets the [default control mode](#) of the instrument (contrary to changing the control mode digitally).

3.8.4 Network settings - readout/change

Reading network settings

- By briefly pressing the switch 3 times with intervals of up to 1 second in normal operation mode, the instrument shows its current node address and baud rate with a series of consecutive LED indication patterns:

Step	Pattern	Indication
1.	Green  	number of flashes indicates the tens of the node address
2.	Red  	number of flashes indicates the units of the node address
3.	Green and red (simultaneous)  	number of flashes indicates the baud rate

Examples:

- for node address 35, the green LED will flash 3 times and the red LED 5 times
- for node address 116, the green LED will flash 11 times and the red LED 6 times









On DeviceNet™ the node address is called MAC ID.

The number of flashes for the baud rate indication is associated with the following baud rates:

Number of flashes (index)	Baud rate					
	FLOW-BUS	Modbus	PROFIBUS DP	DeviceNet™	EtherCAT®	PROFINET
0			automatically detected			
1	187500	9600	9600	125000	100000000	100000000
2	400000	19200	19200	250000		
3		38400	45450	500000		
4		56000	93750			
5		57600	187500			
6		115200	500000			
7		128000	1500000			
8		256000	3000000			
9			6000000			
10			12000000			

Changing network settings

- By briefly pressing the switch 5 times with intervals of up to 1 second in normal operation mode, the instrument enters a state in which the node address and baud rate can be changed (non-Ethernet based protocols only; for Ethernet based protocols (EtherCAT®, PROFINET), network parameters are configured by the fieldbus master and cannot be set on the instrument).
- Changing network parameters with the multifunctional switch is done in 3 steps, each represented by a LED indication pattern (see table below).
- At the start of each step, the according LED(s) start(s) flashing fast (0.1 second on, 0.1 second off). By pressing and holding the switch, the associated action is started and the flashing slows (0.5 seconds on, 0.5 seconds off).

Step	Pattern	Maximum flash count	Action
1.	Green  	12	set tens of node address
2.	Red  	9	set units of node address
3.	Green and red (simultaneous)  	10*	set baud rate index (number of flashes)

*) maximum count depends on the supported baud rates of the fieldbus. See the baud rate table above for supported baud rates and associated indexes.

To execute a step, follow these instructions:

- Press and hold the switch (flashing slows)
- To select value 0 (zero), release the switch within 1 second, otherwise:
- Count the number of LED flashes
- Release the switch as soon as the required value is reached
- In case you lose count, keep the switch pressed and wait until the flash count reaches its maximum and restarts

On completion of a step, the instrument automatically advances to the next step. When all required steps have been completed, the instrument returns to its normal operation mode.

If the switch is not pressed within 60 seconds after starting a step, all changes in the previous steps are cancelled and the instrument returns to its normal operation mode.

4 Digital parameters

Each instrument is controlled internally by a number of digital parameters, most of which can only be accessed using digital communication. Each communication protocol uses its own methods for communicating with instruments and accessing parameters.

FLOW-BUS

Digital Bronkhorst® instruments can be monitored and operated via RS-232 using the free **FlowWare** software tools for Windows. These tools provide a graphical interface to the [ProPar](#) protocol (used by FLOW-BUS), for monitoring and changing instrument parameters.

The FlowWare toolkit provides functionality for monitoring and operating digital instruments (FlowPlot, FlowView) and selection of the active fluid and configuration of the fieldbus connection (if applicable). For instruments that support the definition and use of multiple fluids FlowTune™ can be used to define and store fluids in the instrument and select the active fluid.

Digital instrument parameters are made accessible by **FlowDDE**, a Dynamic Data Exchange server (DDE) that handles communication between the instrument and (dedicated) client software in Windows (e.g. FlowPlot). FlowDDE can also be used by other client applications, such as Microsoft Office or custom made software, built with third party development software like LabVIEW or a SCADA platform.



The FlowWare tools and associated documentation can be downloaded from the product pages on the Bronkhorst website:
www.bronkhorst.com/products

Modbus

Instruments in a Modbus system can be monitored and operated using third party software as a master device, such as LabVIEW, ModScan, or a Modbus PLC.

PROFIBUS-DP

Instruments in a PROFIBUS DP system can be monitored and operated using third party software as a master device, such as TIA Portal (by Siemens).

To configure a device, a so-called GSD file (General Station Description) has to be loaded into the software. The GSD file contains all necessary configuration information to operate the device in a PROFIBUS DP system, including all available operating parameters with their data types.



A GSD file for Bronkhorst® instruments can be downloaded from the product pages on the Bronkhorst website:
www.bronkhorst.com/products

DeviceNet™

Instruments in a DeviceNet™ system can be monitored and operated using third party software as a master device, such as TIA Portal (by Siemens).

To configure a device, a so-called EDS file (Electronics Data Sheet) can be loaded into the software. The EDS file contains all necessary configuration information to operate the device in a DeviceNet™ system, including communication and network configuration, and all available operating parameters with their data types.



An EDS file for Bronkhorst® instruments can be downloaded from the product pages on the Bronkhorst website:
www.bronkhorst.com/products

PROFINET

Instruments in a PROFINET system can be monitored and operated using third party software as a master device, such as TIA Portal (by Siemens).

To configure a device, a so-called GSDML file (General Station Description Markup Language) can be loaded into the software. The GSDML file contains all necessary information, in XML format, to operate the device in a PROFINET system, including communication and network configuration, and all available operating parameters with their data types.



A GSDML file for Bronkhorst® instruments can be downloaded from the product pages on the Bronkhorst website:
www.bronkhorst.com/products

EtherCAT®

Instruments in an EtherCAT® system can be monitored and operated using third party software as a master device, such as SyCon® (by Hilscher GmbH).

To configure a device, a so-called ESI file (EtherCAT® Slave Information) can be loaded into the software. The ESI file contains all necessary configuration information to operate the device in a EtherCAT® system, including communication and network configuration, and all available operating parameters with their data types.



An ESI file for Bronkhorst® instruments can be downloaded from the product pages on the Bronkhorst website: www.bronkhorst.com/products

4.1 General

This section describes the most commonly used parameters for digital operation of the mini CORI-FLOW. Descriptions are grouped by category in tables as shown below:

Type	Access	Range	FlowDDE	FLOW-BUS	Modbus
[type]	RW	[x]...[y]	[DDE par]	[Pro]/[Par]	[address]/[register]



In this manual, parameter names are printed in italics (reverted to normal where embedded in italics, like in this tip).

Type

Unsigned char	1 byte unsigned integer (0...255)
Unsigned int	2 byte unsigned integer, MSB first (0...65535)
Unsigned long	4 byte unsigned integer, MSB first (0...4294967295)
Float	4 byte floating point, IEEE 32-bit single precision, MSB first
Unsigned char [x]	x byte array (text string)

Access

R	Parameter value can be read
W	Parameter value can be written
	Parameter is secured and only accepts values if parameter <i>Init Reset</i> is set to 'unlocked' first

Range

Some parameters only accept values within a certain range:

[x]	Minimum value of the range
[y]	Maximum value of the range

FlowDDE

Parameter number within FlowDDE

FLOW-BUS

Within the FLOW-BUS protocol (ProPar when using RS-232 communication), parameters are identified by a unique combination of a process number and a parameter number:

[Pro]	Process number
[Par]	Parameter number



Consult the **RS-232 manual** (document no. 9.17.027) for detailed information.

Modbus

In the Modbus protocol, parameters are accessed by specifying their unique decimal register number or corresponding PDU address (Protocol Data Unit). The PDU address is the hexadecimal translation of the register number minus 1, e.g. register number 1 corresponds to PDU address 0x0000, register number 11 corresponds to PDU address 0x000A:

[address]	Hexadecimal PDU address
[register]	Decimal register number

Modbus address blocks are two bytes big. Larger data types use up to 8 subsequent address blocks, resulting in a maximum variable length of 16 bytes. Values longer than the maximum length are truncated.

Other interface protocols

Consult the specific fieldbus manual for accessing parameters using fieldbus communication (see [Documentation](#)).



A summary of all digital parameters described in this section can be found in the back of this manual.

4.2 Device identification**User Tag**

Type	Access	Range	FlowDDE	FLOW-BUS	Modbus
Unsigned char[16]	RW	-	115	113/6	0xF130...0xF137/ 61745...61752

With this parameter, the instrument can be given a custom tag name, with a maximum of 16 characters.

Customer Model

Type	Access	Range	FlowDDE	FLOW-BUS	Modbus
Unsigned char[16]	RW	-	93	113/4	0xF120...0xF127/ 61729...61736

This parameter is used to add extra information to the model number information, such as a customer-specific model number.

Serial Number

Type	Access	Range	FlowDDE	FLOW-BUS	Modbus
Unsigned char[20]	R	-	92	113/3	0xF118...0xF11F/ 61721...61728

Instrument serial number for identification.

BHT Model Number

Type	Access	Range	FlowDDE	FLOW-BUS	Modbus
Unsigned char[35]	RW	-	91	113/2	0xF110...0xF117/ 61713...61720

This parameter shows the Bronkhorst® instrument model type information.

Firmware Version

Type	Access	Range	FlowDDE	FLOW-BUS	Modbus
Unsigned char[6]	R	-	105	113/5	0xF128...0xF12A/ 61737...61739

Revision number of the firmware

Identification Number

Type	Access	Range	FlowDDE	FLOW-BUS	Modbus
Unsigned char	RW	0...255	175	113/12	0x0E2C/3629

Bronkhorst® (digital) device type identification number.

Device Type

Type	Access	Range	FlowDDE	FLOW-BUS	Modbus
Unsigned char[6]	R	-	90	113/1	0xF108...0xF10A/ 61705...61707

Device type information string; this parameter contains an abbreviation referring to the identification number.

4.3 Measurement and control

Measure

Type	Access	Range	FlowDDE	FLOW-BUS	Modbus
Unsigned int	R	0...41942 (65535*)	8	1/0	0x0020/33

This parameter indicates the flow metered by the instrument. The value of 32000 corresponds to 100%, the maximum measured value output is 131.07%, which translates to 41942.



*In case the instrument is prepared for bi-directional measurement, the negative signals with an output range of -73.73...-0.003% are represented by the range of 41943...65535, whereas the positive signals 0...131.07% are still represented by the range of 0...41942. (FlowDDE converts the numbers to negative values automatically).

Setpoint

Type	Access	Range	FlowDDE	FLOW-BUS	Modbus
Unsigned int	RW	0...32000	9	1/1	0x0021/34

This parameter is used to set the required flow rate for the controller. The signals have the same range as *Measure*, but the setpoint range is limited between 0 and 100% (0...32000).

Temperature

Type	Access	Range	FlowDDE	FLOW-BUS	Modbus
Float	R	-250...500	142	33/7	0xA138...0xA139/41273...41274

This parameter returns the temperature in °C on the outside of the sensor tube, which is an approximation of the actual media temperature.

Pressure

Type	Access	Range	FlowDDE	FLOW-BUS	Modbus
Float	RW	0...3.4E+38	143	33/8	0xA140...0xA141/41281...41282

In case an external pressure sensor is connected, this parameter returns the actual system pressure in bar(a). If there is no external pressure sensor, the default value of this parameter is equal to parameter *Inlet pressure*.

Density Actual

Type	Access	Range	FlowDDE	FLOW-BUS	Modbus
Float	R	0...3.4E+38	270	116/15	0xF400...0xF401/62465...62466

This parameter returns the actual density measured by the instrument in kg/m³. If the selected *Capacity Unit* is a volume flow type, the instrument uses this parameter for conversion of the measured mass flow to the selected unit.

4.3.1 Advanced measurement and control

Fmeasure

Type	Access	Range	FlowDDE	FLOW-BUS	Modbus
Float	R	-3.4E+38... 3.4E+38	205	33/0	0xA100...0xA101/ 41217...41218

Floating point variant of *Measure*. *Fmeasure* shows the measured value in the capacity unit for which the instrument is set. The instrument uses parameters *Capacity*, *Capacity0%*, *Capacity Unit* and *Sensor Type* to calculate *Fmeasure*.

Fsetpoint

Type	Access	Range	FlowDDE	FLOW-BUS	Modbus
Float	RW	0...3.4E+38	206	33/3	0xA119...0xA11A/ 41241...41242

Floating point variant of *Setpoint*. *Fsetpoint* shows the setpoint in the capacity unit for which the instrument is set. Like *Fmeasure*, *Fsetpoint* is dependent of *Capacity*, *Capacity0%*, *CapacityUnit* and *Sensor Type*.

Setpoint Slope

Type	Access	Range	FlowDDE	FLOW-BUS	Modbus
Unsigned int	RW	0...30000	10	1/2	0x0022/35

The value of this parameter represents the time it would take to adjust the setpoint if it were changed from 0 to 100%. This feature can be used to smooth 'nervous' controller behavior, e.g. to reduce setpoint overshoot or undershoot. The supported range corresponds to 0...3000 seconds. Default value = 0.

Example:

If *Setpoint Slope* = 100 it will take 10 seconds to adjust the setpoint if it is changed from 0 to 100%. A setpoint change of 20% will take $(20\%/100\%)*10$ seconds = 2 seconds.

Analog Input

Type	Access	Range	FlowDDE	FLOW-BUS	Modbus
Unsigned int	R	0...65535	11	1/3	0x0023/36

This parameter contains a digital translation of the analog input signal (if applicable).

Valve Output

Type	Access	Range	FlowDDE	FLOW-BUS	Modbus
Unsigned long	RW	0... 16777215	55	114/1	0xF208...0xF209/61961...61962

This parameter represents the controller output signal for control valve operation.

Sensor Type

Type	Access	Range	FlowDDE	FLOW-BUS	Modbus
Unsigned char	RW 	0...255	22	1/14	0x002E/47

The following sensor types are supported:

Instrument type	Value	Description
Controller	0	Pressure (counter disabled)
	1	Liquid volume
	2	Liquid /gas mass
	3	Gas volume
	4	Other (counter disabled)
Sensor	128	Pressure (counter disabled)
	129	Liquid volume
	130	Liquid/gas mass
	131	Gas volume
	132	Other (counter disabled)

4.4 Alarms



Alarm settings are most easily accessible using FlowPlot or FlowView or a Bronkhorst® readout and control unit.

The built-in alarm functionality can be used to handle different alarm types:

- system errors and warnings
- min/max alarms
- response alarms
- batch alarms
- master/slave alarms

The used alarm type can be set with parameter *Alarm Mode*. When an alarm is activated, the type can be read out using parameter *Alarm Info*. An automatic setpoint change can be set using the parameters *Alarm Setpoint Mode* and *Alarm New Setpoint*. It is also possible to set an alarm delay, to prevent overreaction to small disturbances, using parameter *Alarm Delay Time*. The methods by which an alarm can be reset are controlled by *Reset Alarm Enable*.

Alarm Mode

Type	Access	Range	FlowDDE	FLOW-BUS	Modbus
Unsigned char	RW	0...3	118	97/3	0x0C23/3108

Available modes:

Value	Description
0	Alarm off
1	Alarm on absolute limits
2	Alarm on limits related to setpoint (response alarm)
3	Alarm at power-up(e.g. after power-down)

(On DeviceNet™ instruments, only modes 0 and 1 are available)

Alarm Info

Type	Access	Range	FlowDDE	FLOW-BUS	Modbus
Unsigned char	R	0...255	28	1/20	0x0034/53

This parameter provides information about the event type(s) that triggered an alarm situation. The value is a bitwise summation of the issued alarm types; convert the value to binary to see which types are issued. The following alarm types can be issued:

Bit	Value	Type	Description
0	1	Error	Error flag raised
1	2	Warning	Warning flag raised
2	4	Minimum alarm	<i>Measure < Alarm minimum limit</i>
3	8	Maximum alarm	<i>Measure > Alarm maximum limit</i>
4	16	Batch counter alarm	Batch counter reached its limit
5	32	<ul style="list-style-type: none"> • This bit only: Power-up alarm • If combined with bit 2 or 3: Response alarm 	Alarm possibly caused by a power dip Difference between <i>Measure</i> and <i>Setpoint</i> too big
6	64	Master/slave alarm	Setpoint out of limits (caused by <i>Slave factor</i>)
7	128	Hardware alarm	Hardware error

Alarm Delay Time

Type	Access	Range	FlowDDE	FLOW-BUS	Modbus
Unsigned char	RW	0...255	182	97/7	0x0C27/3112

This value represents the time in seconds the alarm action will be delayed when an alarm limit has been exceeded. This value also delays the alarm off action if an alarm limit is no longer exceeded.
Default value = '0'.

Alarm Maximum Limit

Type	Access	Range	FlowDDE	FLOW-BUS	Modbus
Unsigned int	RW	0...32000	116	97/1	0x0C21/3106

Maximum limit for *Measure* to activate the maximum alarm situation (after *Alarm Delay Time*). Range 0...32000 represents 0...100% signal. *Alarm Maximum Limit* must be greater than *Alarm Minimum Limit*.
Default value: 0.

Alarm Minimum Limit

Type	Access	Range	FlowDDE	FLOW-BUS	Modbus
Unsigned int	RW	0...32000	117	97/2	0x0C22/3107

Minimum limit for *Measure* to activate the minimum alarm situation (after *Alarm Delay Time*). Range 0...32000 represents 0...100% signal. *Alarm Minimum Limit* must be smaller than *Alarm Maximum Limit*.
Default value: 0.

Alarm Setpoint Mode

Type	Access	Range	FlowDDE	FLOW-BUS	Modbus
Unsigned char	RW	0...1	120	97/5	0x0C25/3110

Specifies whether or not to change the setpoint after an alarm situation is activated.

Value	Description
0	No setpoint change (default)
1	Change setpoint to <i>Alarm new setpoint</i>

Alarm New Setpoint

Type	Access	Range	FlowDDE	FLOW-BUS	Modbus
Unsigned int	RW	0...32000	121	97/6	0x0C26/3111

New (safe) setpoint during an alarm until reset. Range 0...32000 represents 0...100% setpoint.
Default value: 0

Reset Alarm Enable

Type	Access	Range	FlowDDE	FLOW-BUS	Modbus
Unsigned char	RW	0...15	156	97/9	0x0C29/3114

Available reset methods for alarms. Up to 4 different methods can be specified; convert the value to binary to see which methods are enabled.
Default value: 15 (all bits/methods enabled)

The following methods are supported:

Bit	Value	Description
0	1	Multifunctional switch
1	2	Externally (deprecated)
2	4	By parameter <i>Reset</i>
3	8	Automatically (when alarm conditions no longer apply)

4.5 Counter

Counter settings are most easily accessible using *FlowPlot* or *FlowView* or a *Bronkhorst®* readout and control unit.

Counter Mode

Type	Access	Range	FlowDDE	FLOW-BUS	Modbus
Unsigned char	RW	0...2	130	104/8	0x0D08/3337

Available modes:

Value	Description
0	Counter off (default)
1	Counting up continuously
2	Counting up until limit reached (set by <i>Counter Limit</i>)

Counter Unit

Type	Access	Range	FlowDDE	FLOW-BUS	Modbus
Unsigned char[4]	RW	see table below	128	104/7	0xE838...0xE839/59449...59450

This parameter contains the name of the counter readout unit.

Counter Unit supports the following values:

Mass	Normal volume (1.01325 bar(a), 0 °C)	Standard volume (1.01325 bar(a), 20 °C)	Custom volume (<i>Capacity Unit Pressure</i> , <i>Capacity Unit Type</i> <i>Temperature</i>)
ug, mg, g, kg	uln, mln, ln, mm3n, cm3n, dm3n, m3n	uls, mls, ls, mm3s, cm3s, dm3s, m3s	ul, ml, l, mm3, cm3, dm3, m3

Counter Value

Type	Access	Range	FlowDDE	FLOW-BUS	Modbus
Float	RW	0... 10000000	122	104/1	0xE808...0xE809/59401...59402

Current counter value in units selected with parameter *Counter Unit*.

Counter Limit

Type	Access	Range	FlowDDE	FLOW-BUS	Modbus
Float	RW	0...9999999	124	104/3	0xE818...0xE819/59417...59418

Counter limit/batch size in units selected with parameter *Counter Unit*.

Default value: 0.

Counter Setpoint Mode

Type	Access	Range	FlowDDE	FLOW-BUS	Modbus
Unsigned char	RW	0...1	126	104/5	0x0D05/3334

Specifies whether or not to change the setpoint after reaching the counter limit.

Value	Description
0	No setpoint change (default)
1	Change setpoint to <i>Counter new setpoint</i>

Counter New Setpoint

Type	Access	Range	FlowDDE	FLOW-BUS	Modbus
Unsigned int	RW	0...32000	127	104/6	0x0D06/3335

New (safe) setpoint when a counter limit is reached until reset. Range 0...32000 represents 0...100% setpoint.

Default value: 0

Reset Counter Enable

Type	Access	Range	FlowDDE	FLOW-BUS	Modbus
Unsigned char	RW	0...15	157	104/9	0x0D09/3338

Available reset methods for counters. Up to 3 different methods can be specified. The value is a bitwise summation of the enabled reset methods; convert the value to binary to see which methods are enabled.
Default value: 7 (bits/methods 0, 1 and 2 enabled)

The following methods are supported:

Bit	Value	Description
0	1	Micro-switch
1	2	Externally
2	4	By parameter <i>Reset</i>
3	8	Automatically (e.g. when counter value is reset)

4.6 Network configuration

Changes made to the network settings will **not** be restored by a factory reset.

Default settings

Network configuration is done ex factory as indicated on the serial number label or in the technical specifications. The table below shows the supported configurations for the available interface protocols (default settings are printed in boldface):

Protocol	ProPar (RS-232)	FLOW-BUS (RS-485)	Modbus (RTU/ASCII)	PROFIBUS DP	DeviceNet™
Address	3	3 ...125	1 ...247	0... 126	0... 63
Baud Rate	9600 19200 38400 57600 115200 230400 460800	187500 400000	9600 19200 38400 56000 57600 115200 128000 256000	(autodetect) 9600 19200 45450 93750 187500 500000 1500000 3000000 6000000 12000000	125000 250000 500000
Parity	0	0	0, 1, 2	2	0

Network configuration for EtherCAT® and PROFINET is done automatically via the Ethernet protocol.

Communication via fieldbus connection (top connector, RS485)

Using the RS232 interface, set the following parameters to configure the instrument for communication via the fieldbus connection:

Fieldbus 1 Address

Type	Access	Range	FlowDDE	FLOW-BUS	Modbus
Unsigned char	RW	0...255	199	125/10	0x0FAA/4011

Fieldbus 1 Baud Rate

Type	Access	Range	FlowDDE	FLOW-BUS	Modbus
Unsigned long	RW	0...1.0E10	201	125/9	0xFD48...0xFD49/64841...64842

Fieldbus 1 Parity

Type	Access	Range	FlowDDE	FLOW-BUS	Modbus
Unsigned char	RW 	0...2	335	125/12	0x0FAC/4013

The following values are supported:

Value	Description
0	No parity
1	Odd parity
2	Even parity

Communication via standard connection (RS232/RS485)

Use the following parameters to configure the instrument for FLOW-BUS or Modbus communication via the 9-pin D-sub side connector:



- If the 9-pin D-sub connector is set for RS-485 communication, the instrument will not respond when connected to an RS-232 configuration. In that case, use the power-up functionality of the [multifunctional switch](#) to enter configuration mode and enable RS-232 communication.
- After configuring the required parameters, use the same procedure to leave configuration mode and restore the original communication settings (otherwise, configuration mode remains enabled after power down).

Fieldbus 2 Address

Type	Access	Range	FlowDDE	FLOW-BUS	Modbus
Unsigned char	RW 	0...255	309	124/10	0x0F8A/3979

Fieldbus 2 Baud Rate

Type	Access	Range	FlowDDE	FLOW-BUS	Modbus
Unsigned long	RW 	0...1.0E10	310	124/9	0xFC48...0xFC49/64585...64586

Fieldbus 2 Parity

Type	Access	Range	FlowDDE	FLOW-BUS	Modbus
Unsigned char	RW 	0...2	336	124/12	0x0F8C/3981

The following values are supported:

Value	Description
0	No parity
1	Odd parity
2	Even parity

4.7 Special parameters

Init Reset

Type	Access	Range	FlowDDE	FLOW-BUS	Modbus
Unsigned char	RW	82/64	7	0/10	0x000A/11

Init Reset is used to unlock secured parameters (marked with a  symbol) for writing. It supports the following values:

Value	Description
64	unlocked, secured parameters can be read and written to
82	locked, secured parameters are read-only

At power-up, *Init Reset* is always set to 'Locked' (value 82).

Reset

Type	Access	Range	FlowDDE	FLOW-BUS	Modbus
Unsigned char	R	0...7	114	115/8	0x0E68/3689

This parameter is used to reset the program, counter or alarms.

Value	Description
0	No reset
1	Reset counter
2	Reset alarm
3	Reset counter
4	Reset and disable counter
5	Reset firmware program (soft reset)
6	Reset <i>Alarm info</i> error bit
7	Reset <i>Alarm info</i> warning bit



The Reset parameter may be disabled by Reset Alarm Enable or Reset Counter Enable. Make sure the value is accepted by sending value 0 first.

Wink

Type	Access	Range	FlowDDE	FLOW-BUS	Modbus
Unsigned char [27]	W	0...9*	1	0/0	0x0000/1

Sending any text string value between 1 and 9 to this parameter makes the indication LEDs (if present) blink for a couple of seconds. This can be useful in order to identify a specific device in a large fieldbus network.

*) Modbus only supports value 14592

Control Mode

Type	Access	Range	FlowDDE	FLOW-BUS	Modbus
Unsigned int	RW	0...255	12	1/4	0x0024/37

Control Mode is used to select different control modes of the instrument and determines from which source(s) it accepts a setpoint. The following control modes are available:

Value	Mode	Instrument action	Setpoint source
0	BUS/RS232	Controlling	Fieldbus/RS-232
1	Analog Input	Controlling	Analog input
2	FLOW-BUS Slave	Acting as slave instrument on FLOW-BUS	RS-485 only: FLOW-BUS master output x <i>Slave Factor</i> /100%
3	Valve Close	Controller disabled, valve closed	
4	Controller Idle	Controller disabled, valve frozen in current position	
7	Setpoint 100%	Controlling, setpoint fixed to 100%	
8	Valve Fully Open	Controller disabled, valve fully opened	
9	Calibration Mode	Calibration mode enabled (factory only)	
10	Analog Slave	Acting as slave of other instrument in analog mode	<i>Analog Input</i> x <i>Slave Factor</i> /100%
12	Setpoint 0%	Controlling, setpoint fixed to 0%	
13	FLOW-BUS Analog Slave	Acting as slave of other instrument on FLOW-BUS, slave factor is set by analog input signal	RS-485 only: FLOW-BUS master output x <i>Analog Input</i>
18	RS232	Controlling, safe state deactivated	Fieldbus/RS-232
20	Valve Steering	Controller disabled, setpoint redirected to <i>Valve output</i>	
21	Analog Valve	Controller disabled, analog input redirected to <i>Valve output</i>	

Value	Mode	Instrument action	Setpoint source
	Steering		
22	Valve Safe State	Force instrument in safe state	

Immediately after power-up, *Control Mode* is set to 'Analog input' or 'BUS/RS232' automatically, depending on the (requested) default setting for analog or digital operation. If *Control mode* is set to value 0, 1, 9 or 18, the instrument returns to its default control mode at the next power-up or reset. Other values are retained after power-up or reset.

4.7.1 Default control mode

IO Status

Type	Access	Range	FlowDDE	FLOW-BUS	Modbus
Unsigned char	RW 	0...255	86	114/11	0x0E4B/3660

The instrument is set to accept a setpoint from either an analog or a digital source. Although this setting can be changed with parameter [Control Mode](#), the instrument usually returns to its default control mode at every power-up or reset. The default control mode can be set with parameter *IO Status*; to change it, use the procedures as described below.

Changing from digital operation to analog operation:

1. Set parameter *Init Reset* to 64 (unlocked)
2. Read parameter *IO Status*
3. Add 64 to the read value
4. Write the new value to parameter *IO Status*
5. Set parameter *Init Reset* to 82 (locked)

Changing from analog operation to digital operation:

1. Set parameter *Init Reset* to 64 (unlocked)
2. Read parameter *IO Status*
3. Subtract 64 from the read value
4. Write the new value to parameter *IO Status*
5. Set parameter *Init Reset* to 82 (locked)



The procedures described above do not change the value of parameter *Control Mode* directly. To apply the new default control mode immediately, change the value of parameter *Control Mode* manually or reset or restart the instrument.



Do not use this procedure if one of the following customized I/O options is installed:

- C5S (digital output, enabled by setpoint)
- I3C (digital input, controller mode valve close)
- I8C (digital input, controller mode valve purge)

4.8 Fluid set

Fluid Set Index

Type	Access	Range	FlowDDE	FLOW-BUS	Modbus
Unsigned char	RW	0...7	24	1/16	0x0030/49

With this parameter, any of the pre-configured fluids (up to 8) can be selected. Each fluid has its specific (configurable) properties, such as *Fluid Name*, *Capacity*, etc.
Default value: 0 (fluid 1).

Note that the selected value is equal to the fluid number minus 1 (value 0 corresponds to fluid 1, value 1 to fluid 2, etc.)

Fluid Name

Type	Access	Range	FlowDDE	FLOW-BUS	Modbus
Unsigned char[10]	RW 	-	25	1/17	0x8188...0x818C/33161...33165

This parameter contains the name of the current fluid.

Capacity

Type	Access	Range	FlowDDE	FLOW-BUS	Modbus
Float	RW 	1E-10... 1E+10	21	1/13	0x8168...0x8169/33129...33130

This parameter sets the maximum readout/control value (100%) for the current fluid in readout units corresponding to *Capacity Unit*.

Capacity Unit

Type	Access	Range	FlowDDE	FLOW-BUS	Modbus
Unsigned char[7]	RW 	see below	129	1/31	0x81F8...0x81FB/33273...33276

Available units:

Mass flow	Normal volume flow (1.01325 bar(a), 0 °C)	Standard volume flow (1.01325 bar(a), 20 °C)	Custom volume flow (<i>Capacity Unit Type Pressure</i> , <i>Capacity Unit Type Temperature</i>)
ug/h, ug/min, ug/s, mg/h, mg/min, mg/s, g/h, g/min, g/s, kg/h, kg/min, kg/s	uln/h, uln/min, uln/s, mln/h, mln/min, mln/s, ln/h, ln/min, ln/s, ccn/h, ccn/min, ccn/s, mm3n/h, mm3n/m, mm3n/s, cm3n/h, cm3n/m, cm3n/s, m3n/h, m3n/min, m3n/s, scfh, scfm, scfs, sccm, slm	uls/h, uls/min, uls/s, mls/h, mls/min, mls/s, ls/h, ls/min, ls/s, ccs/h, ccs/min, ccs/s, mm3s/h, mm3s/m, mm3s/s, cm3s/h, cm3s/m, cm3s/s, m3s/h, m3s/min, m3s/s	ul/h, ul/min, ul/s, ml/h, ml/min, ml/s, l/h, l/min, l/s, cc/h, cc/min, cc/s, mm3/h, mm3/m, mm3/s, cm3/h, cm3/m, cm3/s, m3/h, m3/min, m3/s, cfh, cfm, cfs



Because of the maximum string length (7 characters), some unit names are abbreviated. For instance mm3n/m means mm³n/min.

Capacity Unit Type Temperature

Type	Access	Range	FlowDDE	FLOW-BUS	Modbus
Float	RW 	-273.15... 3.4E+38	245	33/10	0xA150...0xA151/41297...41298

This parameter defines a reference temperature for conversion of the measured mass flow to a volume flow. See also parameters *Capacity Unit* and *Counter Unit*.

Capacity Unit Type Pressure

Type	Access	Range	FlowDDE	FLOW-BUS	Modbus
Float	RW 	0...3.4E+38	246	33/11	0xA158...0xA159/41305...41306

This parameter defines a reference pressure for conversion of the measured mass flow to a volume flow. See also parameters *Capacity Unit* and *Counter Unit*.

4.8.1 Advanced fluid set parameters

Note that the parameters described in this section do not contain any actual measurement values, but only fixed reference values, which can be used for capacity calculations, etc.

Inlet Pressure

Type	Access	Range	FlowDDE	FLOW-BUS	Modbus
Float	RW 	0...3.4E+38	178	113/13	0xF168...0xF169/61801...61802

Inlet pressure of the current fluid in bar(a)

Outlet Pressure

Type	Access	Range	FlowDDE	FLOW-BUS	Modbus
Float	RW 	0...3.4E+38	179	113/14	0xF170...0xF171/61809...61810

Outlet pressure of the current fluid in bar(a).

Fluid Temperature

Type	Access	Range	FlowDDE	FLOW-BUS	Modbus
Float	RW 	-250...500	181	113/16	0xF180...0xF181/61825...61826

Temperature of the current fluid in °C.

Density

Type	Access	Range	FlowDDE	FLOW-BUS	Modbus
Float	RW 	0...3.4E+38	170	33/21	0xA1A8...0xA1A9/41385...41386

Density of the current fluid in kg/m³

4.9 Master/slave configuration (FLOW-BUS)

Normally, there is no communication between slave instruments in a fieldbus system. The FLOW-BUS protocol, however, provides a feature to set up a master/slave relationship between two instruments. The typical behavior of a slave instrument is to automatically set its own setpoint relative to the output (measurement value) of its master.

The output value of any instrument connected to a FLOW-BUS network is automatically available to all other instruments without extra wiring. A slave instrument can in turn be a master to other instruments.

To setup a master/slave relationship between instruments, first determine which instrument should be the master and which should be the slave, then set *Control Mode* of the slave instrument to 'FLOW-BUS Slave' (value 2) or 'FLOW-BUS Analog Slave' (value 13), depending on how the setpoint should be calculated (see parameter [Control Mode](#)).

The slave instrument polls the output value of its master periodically and uses the slave factor to set its own flow relative to the master's.



Setpoints from master instruments can be received via FLOW-BUS only.



To prevent damage to the instruments an/or the system(s) they are connected to, be sure to avoid circular references between devices on the same fieldbus. The FLOW-BUS system does not have a protection mechanism.

Master Node

Type	Access	Range	FlowDDE	FLOW-BUS	Modbus
Unsigned char	RW	1...128	158	33/14	n/a

Set the master node for the instrument

Note that this parameter only is effective in a FLOW-BUS system via RS-485.

Slave Factor

Type	Access	Range	FlowDDE	FLOW-BUS	Modbus
Float	RW	0...500	139	33/1	0xA108...0xA109/41225...41226

The controller output from the master instrument is multiplied by *Slave Factor*/100% to get the slave instrument setpoint. In systems other than FLOW-BUS via RS-485, *Slave Factor* is effective only if *Control Mode* is set to 'Analog slave', and the analog output signal of the master instrument is redirected to the input of the slave instrument.

Example:

- master output = 80%
 - *Slave Factor* = 50
- ⇒ slave instrument setpoint = 80% x 50%/100% = 40%

4.10 Controller

The picture below shows a basic diagram of the PID controller algorithm (proportional, integral, derivative) used by digital Bronkhorst® instruments.

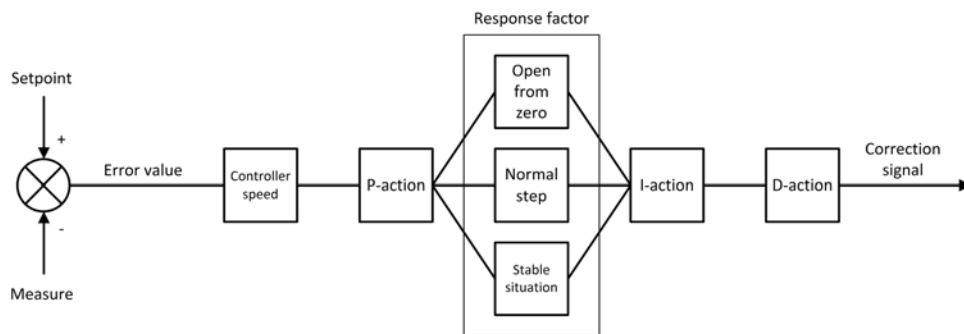

The controller speed controls the overall performance of the controller algorithm. Basically, to adjust the controller response, only the controller speed needs to be changed.

The algorithm is based upon the difference between the setpoint and the measured value (called the error value). The correction signal to eliminate the error is assembled from 3 basic components:

- The P-action (proportional) multiplies the error value by a constant factor, to adjust the measure towards the (new) setpoint.
- The I-action (integral) amplifies the correction signal with a factor depending on the integral of the error value over time.
- The D-action (derivative) reduces the strength of the P-action, to prevent overshoot when the (new) setpoint is reached.

The proportional action is enhanced by one of three additional response factors, depending on the control cycle stage:

- Open from zero: the setpoint is larger than zero and the measured value is below 2% of the full scale range.
- Normal step: the measured value differs more than 2% from the setpoint, typically after changing the setpoint (step).
- Stable situation: the measured value differs less than 2% from the setpoint.



For more information about controlling characteristics, consult the FlowPlot manual (document 9.17.030). This manual can be downloaded from www.bronkhorst.com/downloads.



The control characteristics are optimized during production. These parameters should only be changed if absolutely necessary, and only by or under the supervision of trained service personnel.

Controller Speed

Type	Access	Range	FlowDDE	FLOW-BUS	Modbus
Float	RW	0.2...5	254	114/30	0xF2F0...0xF2F1/62193...62194

This parameter sets the overall controller speed factor for the selected fluid set. *Controller speed* is set ex factory between value '0.5' (slow) and '2' (fast). The default value is '1'.

PID-Kp

Type	Access	Range	FlowDDE	FLOW-BUS	Modbus
Float	RW 	0...1E+10	167	114/21	0xF2A8...0xF2A9/62121...62122

PID controller proportional action, multiplication factor.

PID-Ti

Type	Access	Range	FlowDDE	FLOW-BUS	Modbus
Float	RW 	0...1E+10	168	114/22	0xF2B0...0xF2B1/62129...62130

PID controller integral action in seconds.

PID-Td

Type	Access	Range	FlowDDE	FLOW-BUS	Modbus
Float	RW 	0...1E+10	169	114/23	0xF2B8...0xF2B9/62137...62138

PID controller derivative action in seconds. The default value is 0.0.

Open From Zero Response

Type	Access	Range	FlowDDE	FLOW-BUS	Modbus
Unsigned char	RW 	0...255	165	114/18	0x0E52/3667

Response factor, applied to proportional action when opening the valve from 0%.

- Default value: 128 (no correction)
- Other values adjust the controller gain (correction signal) as follows: $\text{Controller gain} = \text{Controller Speed} * \text{PID-Kp} * 1,05^{(\text{response factor} - 128)}$

Normal Step Response

Type	Access	Range	FlowDDE	FLOW-BUS	Modbus
Unsigned char	RW 	0...255	72	114/5	0x0E45/3654

Response factor, applied to proportional action during normal control (at setpoint step).

- Default value: 128 (no correction)
- Other values adjust the controller gain (correction signal) as follows: $\text{Controller gain} = \text{Controller Speed} * \text{PID-Kp} * 1,05^{(\text{response factor} - 128)}$

Stable Situation Response

Type	Access	Range	FlowDDE	FLOW-BUS	Modbus
Unsigned char	RW 	0...255	141	114/17	0x0E51/3666

Stable situation response, applied when the controller is stable (within a 2% band around the setpoint).

- Default value: 128 (no correction)
- Other values adjust the controller gain (correction signal) as follows: $\text{Controller gain} = \text{Controller Speed} * \text{PID-Kp} * 1,05^{(\text{response factor} - 128)}$

5 Batch dosing with CORI-FILL™

This section describes the steps to be taken in order to prepare the instrument for batch dosing. Once the instrument is configured properly, the **CORI-FILL™** technology controls the dosing process, regardless of the fieldbus system the instrument is installed in. The digital parameters can be monitored (or even controlled) in the usual way. To this end, each configuration step is supplemented with a list of the digital parameters involved.

5.1 Dosing principle

At the start of each batch, the flow is initiated by opening a valve (or starting a pump). The flow meter measures and totalizes the flow, continuously calculating the current batch size (Batch size = Flow x Time, see diagram). As soon as the delivered batch size reaches the configured batch size, the flow is stopped.

Depending on the importance of accuracy as opposed to dosing speed, proportional control or on/off control is advised. Proportional control using a control valve or (gear) pump is the common method if batch size accuracy is of critical importance. On/off control using a shut-off valve is typically used in situations where dosing speed is more important.

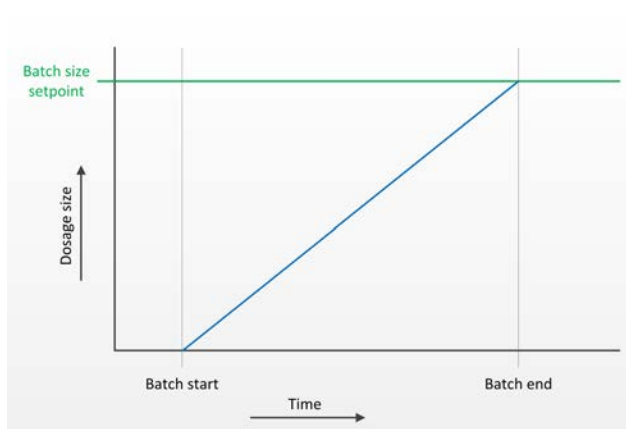

5.1.1 Proportional control

With proportional control, each batch starts with a linear phase, where dosing is done with the highest possible flow rate (flow setpoint = 100%). When the configured batch size is being approached, the flow can be reduced, by gradually closing the valve (or reducing pump speed), until the flow rate reaches zero at the end of the batch (control gain phase).

This proportional optimization method assures accurate dosing from the very first batch, with minimal overshoot.

To compensate for possible dosing speed reduction by the control gain phase, the controller response performance can be enhanced somewhat, by optimizing the PID controller characteristics of the instrument.

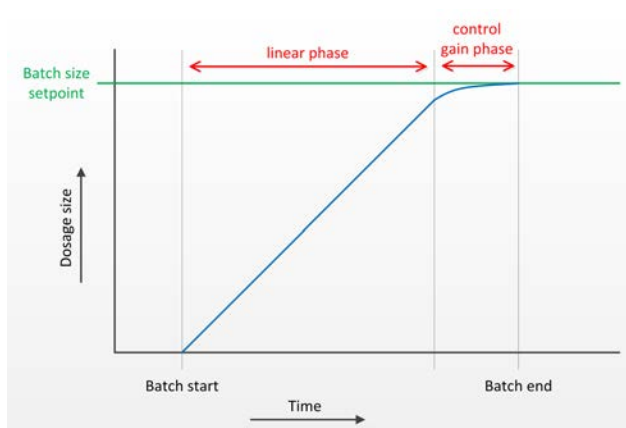

5.1.2 Preventing overshoot

Due to mechanical restrictions, the first dosage in the process will always have some overshoot (delivered batch larger than configured size). This goes for both on/off control and proportional control (even though the control gain phase of the proportional batch cycle assures minimal batch size overshoot).

CORI-FILL™ implements an overrun correction algorithm to prevent batch size overshoot. This automatic self-learning function optimizes the size of each new batch, based on the previously delivered one, until the overshoot is eliminated (typically after 3 batches, assuming the inlet pressure is stable).

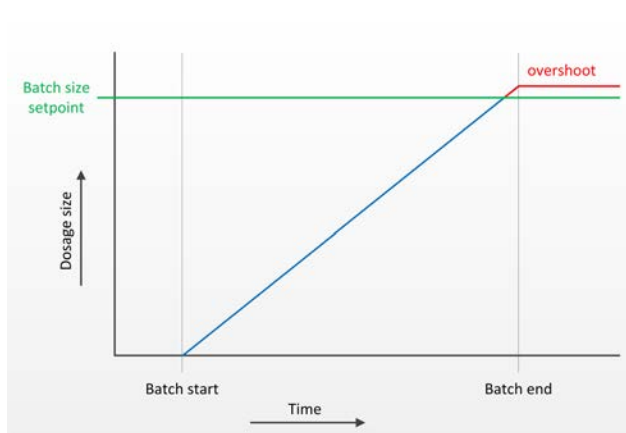

5.1.3 Estimated dosing time

With **proportional control**, the estimated dosing time per batch can be calculated with the following formula:

$$\text{Dosing Time (seconds)} = 2 \text{ seconds} + \frac{\text{Batch Size}}{\text{Full Scale Flow Rate}}$$

With **on/off control**, the estimated dosing time per batch can be calculated with the following formula:

$$\text{Dosing Time (seconds)} = 1 \text{ second} + \frac{\text{Batch Size}}{\text{Maximum Instrument Flow}}$$



Note that with on/off control, the only way to affect the dosing time is by changing the batch size, because the maximum instrument flow cannot be changed. With proportional control, the measuring range of the instrument can be rescaled.



The formulas above depict rough estimations of the expected dosing times. The extra time (2 seconds for proportional control, 1 second for on/off control) is determined experimentally, based on observations made while setting up CORI-FILL using FlowPlot.

5.2 Process conditions



When setting up the instrument for batch dosing, the following considerations are critical for obtaining accurate dosing results:

- Prior to starting batch dosing, adjusting the zero point of the instrument at actual process conditions is recommended (see [Zeroing](#)).
- The inlet pressure should be appropriate and stable. Too high a pressure will cause batch size overshoot, too low a pressure will result in not reaching the configured batch size within an acceptable time frame.
- For liquid dosing, the liquid should not contain any gas bubbles. Gas bubbles act as an 'expansion vessel', destabilizing the flow rate and slowing down response times. Using a degasser is recommended, especially with very small batch sizes and/or times (in the order of mg/ml and ms respectively).
- The amount of piping, reducers, connections and T-parts should be limited to the absolute minimum.
- Tubing/piping size should be appropriate to the flow rate.

5.3 Parameter settings

Preparing the instrument for **CORI-FILL™** batch dosing involves setting a number of parameters, in order to determine the dosing characteristics:

1. [dosing method](#) (volumetric flow or mass flow)
2. [dosage settings](#) (batch dimensions)
3. optimization
 - a. [overrun correction](#)
 - b. [disabling filters](#)
 - c. [proportional control](#) optimization

This section concentrates on configuring the instrument using FlowDDE and FlowPlot. Guidelines given for setting parameter values are based on best practice. For some parameters, the optimal value depends on a number of factors, such as the instrument type, specific dosing requirements and operational circumstances.

For the most part, configuration can be done in the *Instrument Settings* function in FlowPlot. In order to enable communication between FlowPlot and the instrument, the *Control Mode* of the instrument has to be set to RS232 communication (see [Special parameters](#)).



Extensive information about the installation and usage of FlowPlot can be found in the FlowPlot manual (document 9.17.030), which can be downloaded from www.bronkhorst.com/downloads.



- If the 9-pin D-sub connector is set for RS-485 communication, the instrument will not respond when connected to an RS-232 configuration. In that case, use the power-up functionality of the [multifunctional switch](#) to enter configuration mode and enable RS-232 communication.
- After configuring the required parameters, use the same procedure to leave configuration mode and restore the original communication settings (otherwise, configuration mode remains enabled after power down).

5.3.1 Dosing method

With **CORI-FILL™**, batch dosing can be done based on mass or volume flow. By choosing the required unit type, the batch counter is automatically configured to use similar units.

In FlowPlot, the fluid settings for determining the dosing method are located on the *Basic* tab of the *Instrument Settings* function (see image to the right).

For volume flow based dosing, the instrument needs the fluid density to calculate the volume and batch size from the mass flow measured by the instrument. The instrument supports different types of volume measurement. Depending on the specific type selected, the actual (measured by the instrument) or theoretical fluid density is used.

For liquid dosing, FlowPlot supports Mass Flow and Volume Flow; for gas, Mass Flow, Normal Volume Flow or Standard Volume Flow can be selected.

With **Mass Flow**, the instrument does not need extra information to calculate the batch size:

When **Volume Flow**, **Normal Volume Flow** or **Standard Volume Flow** is selected, the instrument needs the theoretical fluid density to calculate the batch volume.

Because Normal Volume Flow and Standard Volume Flow are typical gas flow units, for these unit types the fluid density at normal (0 °C, 1 atm) or standard conditions (20 °C, 1 atm) respectively is needed.

With **Actual Volume Flow**, the actual fluid density, measured by the instrument, is used to calculate the batch volume:



Because the mini CORI-FLOW ML120 measures mass flow, this is also the preferred dosing method. For volume based capacity units, the fluid density is needed to calculate the batch size (see the descriptions below), which is less accurate (and slower) than using the measured mass flow directly.

The following digital parameters are involved in choosing the required dosing method:

Name	Process/Parameter	Modbus Register no	Value	Purpose/Remarks
Capacity Unit (129)	1/31	33273... 33276	as required	select measuring unit (see fluid set parameters for available measuring units)
Density (170)	33/21	41385... 41386	as required	fluid density used to calculate volume flow from mass flow: <ul style="list-style-type: none"> for liquid dosing, use theoretical fluid density for volume based gas dosing, use fluid density at normal (0 °C, 1 atm) or standard conditions (20 °C, 1 atm)

5.3.2 Batch settings



When configuring the instrument for batch dosing, always set New setpoint on limit to 0. With any other value the media flow will not stop after reaching the configured batch size. In that case, dosing can only be stopped by disabling the counter (Counter Mode = Off) and changing the main setpoint to 0.

The counter function of the instrument is used to configure the actual batch parameters. In FlowPlot, these settings are done on the *Alarm & Count* tab of the *Instrument Settings* function:

- For batch dosing, set the counter to totalize the measured flow rate, until the required batch size is reached (Up to limit)
- The counter limit defines the required batch size (note that the selectable counter units automatically match the capacity unit type that was selected by choosing the dosing method)
- By changing the new setpoint to 0 (zero) on reaching the counter limit, the flow is stopped when the configured batch size is delivered
- A new batch can be started by resetting the counter by means of (one of) the configured batch trigger(s)

When testing batch settings in FlowPlot, follow these steps:

- Set the setpoint to 0% (group *Setpoint controller*, see image)
- Click the *Reset counter* button
- Start the first batch by changing the setpoint to 100%
- Wait until the configured counter limit is reached (red indicator in the bottom of the *Counter* group)
- Click *Reset counter* to start a new batch

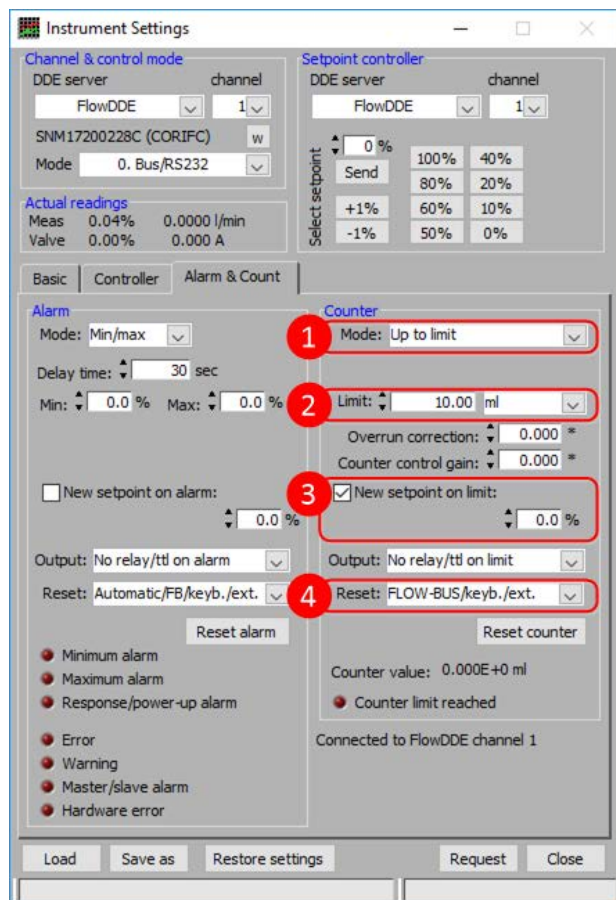

In the table below, the digital counter parameters are described from a batch dosing point of view. See [counter parameters](#) for usage and supported values.

Name	Process/Parameter	Modbus register no	Value	Purpose/Remarks
Counter Unit (128)	104/7	59448... 59449	as required	set dosing unit unit must be from the same category as <i>Capacity Unit</i>
Counter Mode (130)	104/8	3337	2	count until configured batch size is reached
Counter Limit (124)	104/3	59417... 59418	as required	set batch size
Counter Setpoint Mode (126)	104/5	3334	1	change setpoint when configured batch size is reached
Counter New Setpoint (127)	104/6	3335	0	stop flow after reaching batch size
Reset Counter Enable (157)	104/9	3338	as required	enable new batch trigger(s)

5.3.3 Overrun correction

By setting *Counter Controller Overrun Correction* to a value between 0 and 1, the system closes the valve (or stops the pump) a fraction before reaching the batch size, minimizing overshoot.

In FlowPlot, the overrun correction can be set on the *Alarm & Count* tab of the *Instrument Settings* function.

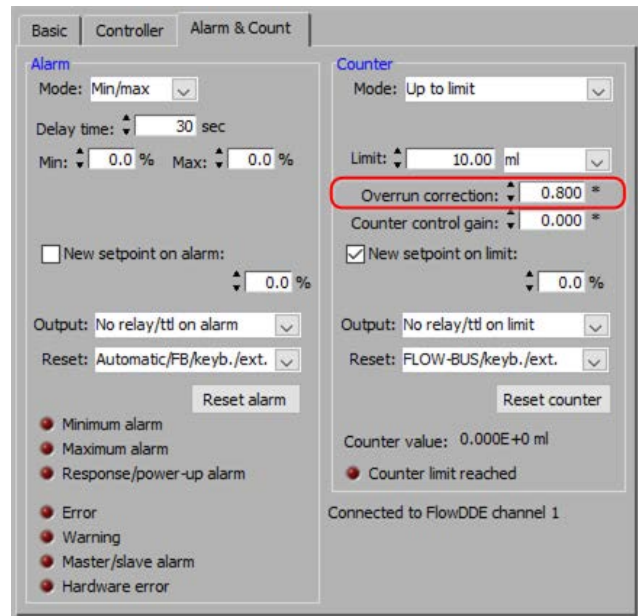

An overrun correction value of 0.8 has proven to be a proper functional value. Higher values will result in faster correction (needing less dosing cycles to eliminate batch size overshoot), but might also result in unstable control behavior.

Overrun correction is set by the following digital parameter:

Name	Process/Parameter	Modbus register no	Value	Purpose/Remarks
Counter Controller Overrun Correction (274)	104/10	59473... 59474	0.8	prevent batch size overshoot <ul style="list-style-type: none"> • higher value: faster correction, less dosing cycles needed • lower value: slower correction, more dosing cycles needed

5.3.4 Disabling filters

Dosing speed can be increased by disabling output and sensor filters. In FlowPlot, filter settings are located on the *Basic* tab of the *Instrument Settings* function. To disable filtering, make sure to set the values as shown in the image to the right.

Disabling filters, however, not only makes the instrument faster, it also makes it more sensitive to vibrations and electrical noise.

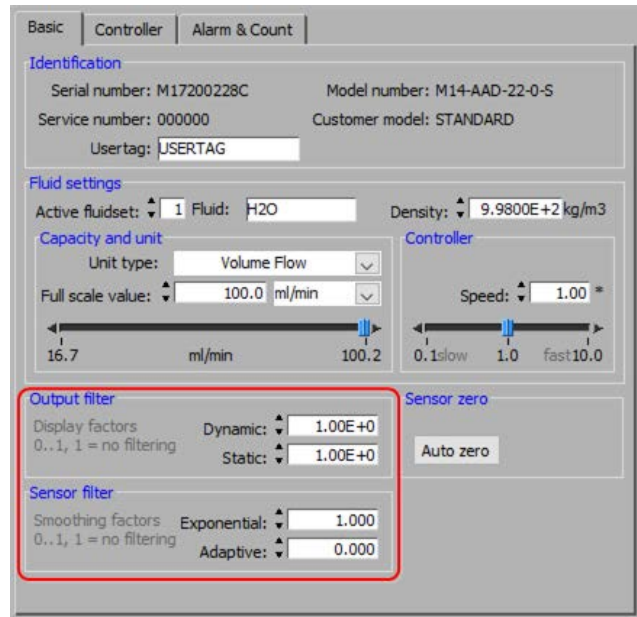

Minimizing sensitivity

The instrument should always be mounted in a vibration free environment (if possible), on the supplied mass block and dampers. Sensitivity to electrical noise can be eliminated by increasing the minimum capacity of the instrument to a value just above the noise level.

The minimum capacity cannot be entered in FlowPlot; instead, use the parameter test function of FlowDDE. To read and write parameters with FlowDDE, proceed as follows:

1. In FlowDDE, open *FLOW-BUS > Test FLOW-BUS and DDE*
2. From the *Parameter* list, select the required parameter
3. In the *Write value* column, enter the required parameter
4. Click the *Write* button to store the value
5. Click the *Read* button to check if the write action has succeeded

The value of *Capacity Minimum (247)* can only be changed after enabling edit mode for secured parameters with parameter *Init Reset (7)*. To set the minimum capacity, enter the required information as shown in the image below (the value of *Capacity Minimum* is illustrative, use the value you need).

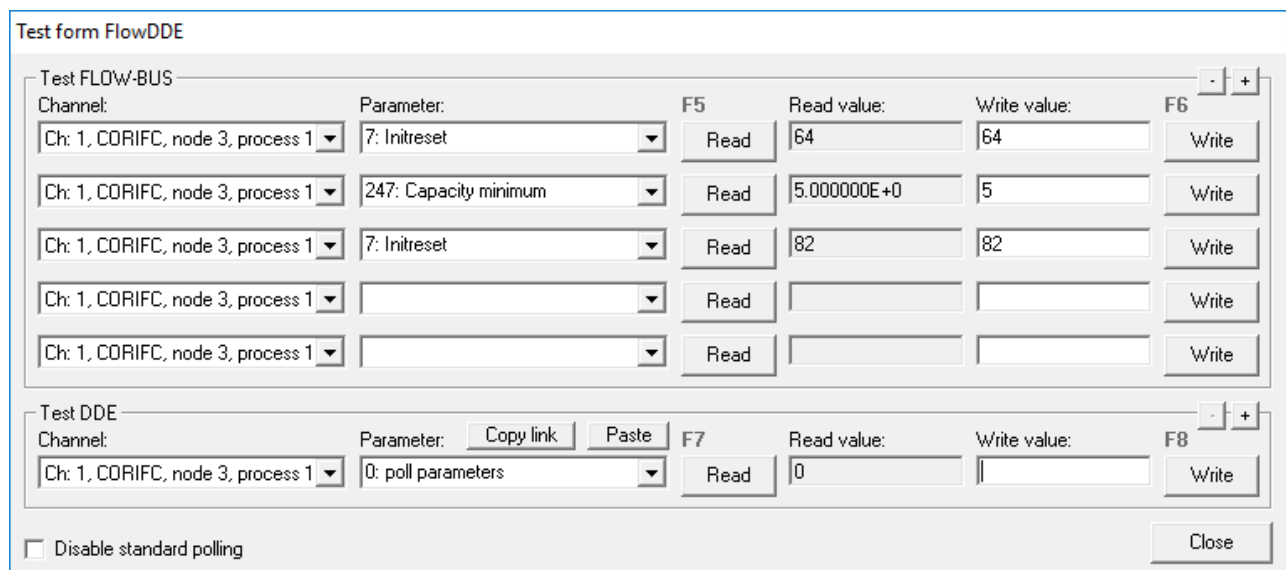

The following digital parameters are involved in the filtering and minimum capacity settings:

Name	Process/Parameter	Modbus register no	Value	Purpose/Remarks
Dynamic Display Factor (56)	117/1	62729... 62730	1	disable filter
Static Display Factor (57)	117/2	62737... 62738	1	disable filter
Sensor Exponential Smoothing Filter (74)	117/4	62753... 62754	1	disable filter
Capacity Minimum (247)	1/27	33241... 33242	as required	typical value (for mini CORI-FLOW ML120): 5 g/h

5.3.5 Proportional control settings

Adjusting flow range

A proportional control valve enables re-scaling of the controllable flow range, making it possible to dose with a lower flow. This increases the running time of the batch (especially in the linear phase; see [Dosing principle](#)), but also provides higher accuracy. To minimize batch size overshoot, the flow can be reduced further when nearing the configured batch size (control gain phase).

To change the maximum capacity in FlowPlot, return to the *Basic* tab of the *Instrument Settings* function and edit the *Full scale* value. In the plotting area of the main screen, this value is translated to 100%.

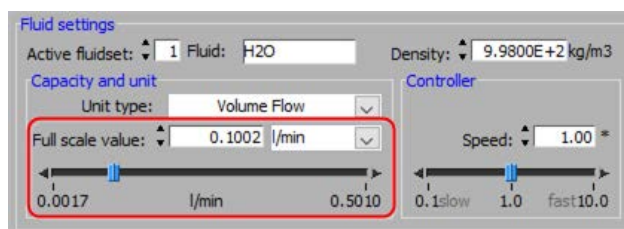

The starting point of the control gain phase is determined by the value of *Counter control gain*. From the start of the controller gain phase, the valve is closed gradually (or the pump speed lowered), until the configured batch size is reached.

The required value can be calculated with the following formula:

$$\text{Counter control gain} = \frac{100\%}{100\% - \text{Percentage of batch delivered}}$$

The table below shows some example values:

Percentage delivered	Counter control gain	
0%	1	
50%	2	▲
75%	4	longer dosing time, less overshoot
80%	5	
90%	10 (default)	●
95%	20	shorter dosing time, more overshoot
98%	50	
99%	100	▼

If the value is set to 0, control gain is disabled. Essentially, this turns proportional control into on/off control.

In FlowPlot, the input location of *Counter control gain* can be found on the *Alarm & Count* tab of the *Instrument Settings*.

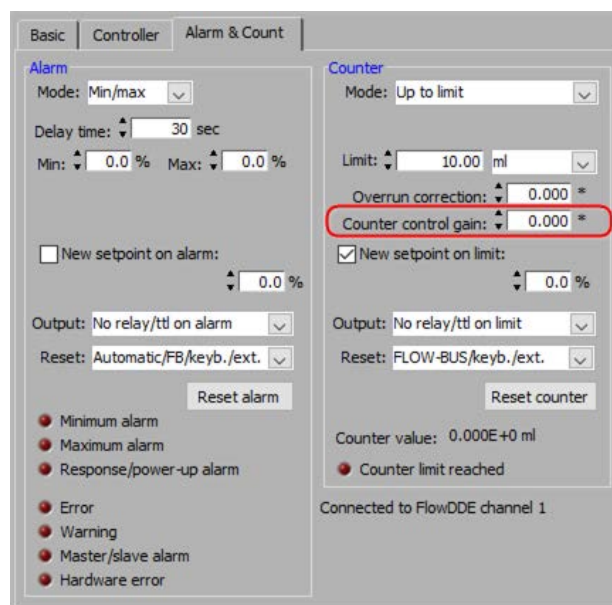



Lower values start the control gain phase earlier, which can lead to exceptionally long dosing times. A minimum value of 10 is recommended (corresponding to 90% of the batch delivered). If this leads to batch size overshoot, consider lowering the maximum capacity (rather than lowering Counter control gain).

The following digital parameters are involved in adjusting the flow progress during each batch:

Name	Process/Parameter	Modbus register no	Value	Purpose/Remarks
Capacity (21)	1/13	33129... 33130	as required	<ul style="list-style-type: none"> set maximum dosing flow analog output signal is re-scaled accordingly (20 mA corresponds to 100% FS)
Counter Controller Gain (275)	104/11	59481... 59482	as required	prevent batch size overshoot by reducing flow when approaching configured batch size

Optimizing controller



The PID controller settings of the instrument are optimized before shipping. Generally, changing these settings is strongly dissuaded. However, for proportional batch dosing, adjusting some of the PID-parameters slightly might prove useful to improve response performance and dosing accuracy.

In FlowPlot, the controller settings are located on the *Controller* tab of the *Instrument Settings*.

1. A control valve (or pump) needs a minimum electrical current (threshold) to open (or start running). Normally, when opening the valve, the current is increased gradually, until the threshold is reached and the valve opens. The time to reach the threshold (dead time) can be minimized, by specifying a starting power/current, just under the threshold. This shortens the valve response time, because the starting power is immediately applied when the valve is opened (instead of gradually).
2. *Setpoint slope* can be used to smooth 'nervous' behavior of the PID controller (reduce setpoint overshoot or undershoot), but with proportional batch dosing, this might lengthen the dosing time unacceptably. The recommended value for *Setpoint slope* is 0.
3. Dosing speed can be increased, by optimizing the PID settings of the controller. Be aware, however, that even small changes might result in violent reactions and unstable control behavior. The recommended values are shown in the image to the right and in the table below.

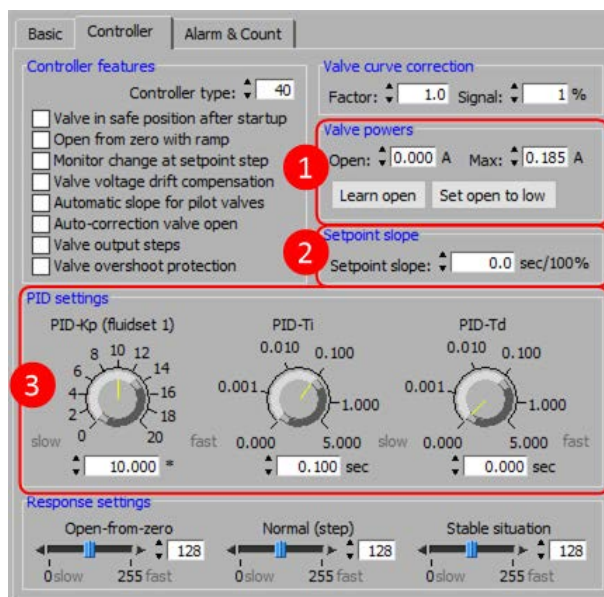

- The required power to open the valve can be determined automatically, by clicking the Learn open button. Note that this only works by (temporarily) disabling the counter (Counter mode = Off; see [Batch settings](#))
- If necessary, the PID dials can be re-scaled by clicking on a scale value and entering a new value.

The following digital parameters are involved in optimizing proportional control:

Name	Process/ Parameter	Modbus register no	Value	Purpose/Remarks
Valve Open (190)	114/24	62145... 62146	as required	set minimum current/voltage required to open the valve
Setpoint Slope (10)	1/2	35	0	adjustment time when changing setpoint from 0% to 100% (range corresponds with 0...3000 seconds)
PID-Kp (167)	114/21	62121... 62122	10	controller proportional action (increase to speed up controller, decrease to slow down)
PID-Ti (168)	114/22	62129... 62130	0.1	controller integral action (decrease to speed up controller, increase to slow down)
PID-Td (169)	114/23	62137... 62138	0	controller derivative action (prevents setpoint overshoot)



For more information about the PID controller, see [Digital parameters - Controller](#) in this manual or the FlowPlot manual (document 9.17.030).

5.3.6 On/off control settings

Minimizing valve temperature

When working with fluids with a low boiling/evaporation point, it can be useful to limit the power dissipation by a shut-off valve, in order to minimize the temperature rise caused by valve actuation. A shut-off valve needs a stronger signal to open it than to keep it open (hold signal). Once it is open, the signal can safely be set to a lower point, reducing power dissipation by the valve coil (thereby minimizing temperature rise).

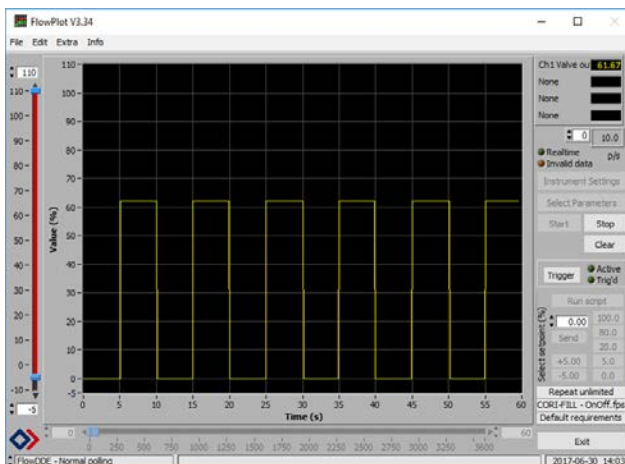

On/off control without hold signal

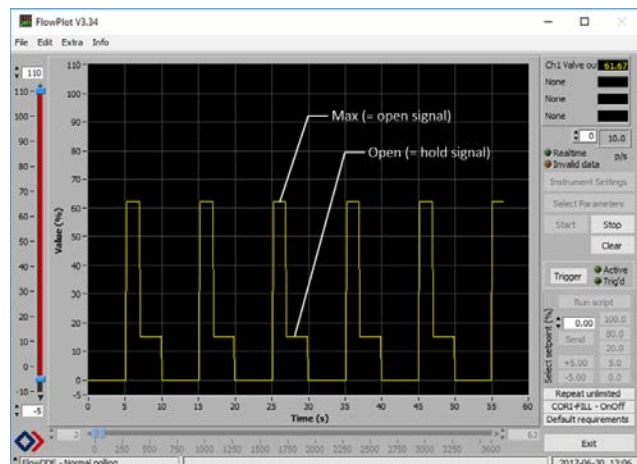

On/off control with hold signal

In FlowPlot, the valve power parameters are set on the *Controller* tab of the *Instrument Settings*:

- *Valve maximum* sets the power needed to fully open the valve
- *Valve open* sets the power needed to keep the valve open (hold signal)

Optimum values might differ, depending on the specifics of the valve.

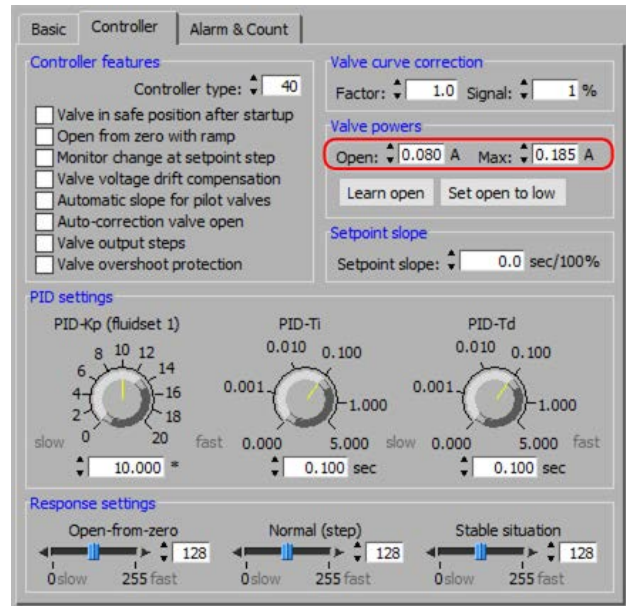

If the use of the valve power parameters seems somewhat counterintuitive, note that usage here is specific to shut-off valves. For control valves, the purpose of the Open and Max parameters is more straightforward.

The valve power settings can be done with the following digital parameters:

Name	Process/Parameter	Modbus register no	Value	Purpose/Remarks
Valve Maximum (231)	114/25	62153... 62154	as required	set minimum power for opening shut-off valve
Valve Open (190)	114/24	62145... 62146	as required	set minimum power to keep the valve open

5.4 Optimizing hints

Problem	Possible cause	Action
Batch size overshoot not reduced after more than 3 batches	Dosing time too short	<ul style="list-style-type: none"> • Decrease inlet pressure • Decrease maximum capacity*
	Counter control gain too high	Decrease counter control gain *
Dosing time too long	Flow rate too low	<ul style="list-style-type: none"> • Increase inlet pressure • Increase maximum capacity*
	Counter control gain too low	Increase counter control gain *
	Controller too slow	Optimize PID controller *
	Pump speed adjustment too slow	Increase controller speed (when using a pump, controller speed values up to 10 can be used)
New batch cannot be started	New batch trigger(s) not defined	Enable new batch trigger(s) (see Batch settings)
Flow continues after configured batch size is reached	<i>New setpoint on limit</i> > 0%	Set <i>New setpoint on limit</i> to 0% (see Batch settings)
Counter value still changes after limit is reached	Measuring signal disturbed by electrical noise	Increase minimum capacity (see Disabling filters)
	Zero point drifted	Adjust zero point (see Zeroing)
	Gas inclusion in tubing	Flush instrument and tubing at relatively high flow rate before starting batch control
	Leakage	Check system for leaks

Problem	Possible cause	Action
	<i>New setpoint on limit</i> > 0%	Set <i>New setpoint on limit</i> to 0% (see Batch settings)
Flow signal too slow	Output filters enabled	Disable filters (see Disabling filters)
<ul style="list-style-type: none"> Delivered batch size inaccurate and/or unstable Delivered batch size does not match counter limit 	Vibrations in instrument surroundings	<ul style="list-style-type: none"> Avoid mounting in close proximity of mechanical vibrations Follow mounting instructions
	Zero point drifted	Adjust zero point (see Zeroing)
	Gas inclusion in liquid	Install degasser
	Inlet pressure unstable	Eliminate pressure fluctuations, e.g. by installing a pressure regulator
	Filter settings not optimized	Disable filters (see Disabling filters)
	Proportional dosing too fast	Decrease counter control gain (see Proportional control settings)*
	Controller settings not optimized	Set overrun correction to 0.8 (see Overrun correction)
Flow signal > 130%	Inlet pressure too high	Decrease inlet pressure
	Liquid tubing resistance too low	Restrict flow e.g. with needle valve or by using tubing with smaller diameter
	Full scale capacity too low	Rescale controllable flow range (see Proportional control settings)*
	Controller settings not optimized	Decrease PID-Kp value (see Proportional control settings)*

*) Proportional control only

6 Troubleshooting and service



See [LED indications](#) for an explanation of all possible LED indications.



In case of problems during operation, error and warning information can be found in FlowDDE and FlowPlot. FlowDDE puts all errors and warnings on the console screen; FlowPlot provides several alarm and counter indicators. See also section [Basic RS232 operation](#).

6.1 Restoring factory settings

In case changes to the instrument configuration leads to non-recoverable erroneous behavior, the instrument can be reset to the pre-configured factory settings. This can be done with the following methods:

- with the multifunctional switch (see [Multifunctional switch](#))
- with the *restore* function of a Bronkhorst® readout and control unit (BRIGHT, E-8000)
- via RS232 communication, with the *Restore settings* function in FlowPlot



Changes made to the network settings (bus address, baud rate, parity) will **not** be restored by a factory reset.



If digital communication with the instrument can not be re-established, see [Multifunctional switch](#) to enter configuration mode, overrule the 9-pin D-sub communication settings and use the RS232 communication mode to re-establish communication.

6.2 Common issues

Symptom	Possible cause	Action
Red LED glows continuously	No liquid in measuring tube	Flush instrument with process fluid prior to starting measurement and control
	Slug flow (combined gas and liquid flow)	Make sure the measuring tube only contains either gas or liquid
	Hardware error	Return equipment to factory
No fieldbus communication	No power supply	<ul style="list-style-type: none"> • Check power supply • Check cable connection • Check cable hook-up
	Invalid node address	Change node address (see Network configuration)
	Other	Reset instrument and/or restart master. Contact Bronkhorst if problem persists.
No output signal	No power supply	<ul style="list-style-type: none"> • Check power supply • Check cable connection • Check cable hook-up
	Inlet pressure or differential pressure too low	Increase inlet pressure
	Piping, filters and/or control valve clogged or blocked	<ul style="list-style-type: none"> • Clean system (flush with clean, dry air or a non-aggressive cleaning liquid (e.g. ethanol or isopropyl alcohol)) • For external proportional control valves: supply 0...15 Vdc and operational inlet pressure to valve and slowly increase voltage. If valve does not open, clean parts and re-adjust valve
	Sensor failure	Return equipment to factory
<ul style="list-style-type: none"> • Control behavior unstable • Red LED flashes irregularly 	Measurement disturbed by mechanical vibration	<ul style="list-style-type: none"> • If possible, avoid installation in close proximity of mechanical vibration

Symptom	Possible cause	Action
		<ul style="list-style-type: none"> Reduce sensitivity to vibrations by using a mass block, dampeners, and flexible tubing
	Inlet pressure unstable	Eliminate pressure fluctuations, e.g. by installing a pressure regulator
	Gas accumulation in tubing	Flush the system to remove gas Tip: use frequency or density signal to detect presence of gas bubbles
	Wrong controller settings	Adjust settings (e.g. with FlowPlot)
No flow (sending a setpoint has no effect)	No fluid supply	Check upstream components for obstruction, e.g.: <ul style="list-style-type: none"> fluid lines valves filters
	Inlet pressure or differential pressure out of bounds	Set inlet pressure to a value within specifications
Flow rate rises, but never reaches setpoint	Piping, filters and/or control valve clogged or blocked	<ul style="list-style-type: none"> Clean system (flush with clean, dry air or a non-aggressive cleaning liquid (e.g. ethanol or isopropyl alcohol)) For external proportional control valves: supply 0...15 Vdc and operational inlet pressure to valve and slowly increase voltage. If valve does not open, clean parts and re-adjust valve
	Inlet pressure too low	Increase inlet pressure
	Outlet pressure too high	Check outlet pressure
	Process outlet blocked	Check process outlet and downstream piping
Measured value or output signal much lower than setpoint	Inlet pressure or differential pressure too low	<ul style="list-style-type: none"> Increase inlet pressure Use instrument in conditions it was designed for
	Piping or filters blocked or contaminated	Clean system
	Sensor blocked or contaminated	Clean sensor
	Valve blocked or contaminated	Clean valve
	Supplied fluid type does not match configured fluid type	Supply equipment with other fluid or change fluid type in instrument configuration
Measured value or output signal indicates a flow, while there should be none	Instrument not mounted horizontally or ambient conditions differ significantly from conditions stated on serial number label	<ul style="list-style-type: none"> Follow mounting instructions Use instrument in conditions it was designed for Adjust zero point (see Zeroing)
	Control valve leaking	Clean valve; if problem persists, return equipment to factory
	System leakage	Check the system for leakage. Follow vendor instructions when installing third party components (e.g. adapters, tubing, valves)
Continuous maximum measured value or output signal	Inlet pressure too high	Check inlet pressure
	Control valve (normally open) failure	Return equipment to factory
	Sensor failure	Return equipment to factory

Symptom	Possible cause	Action
Flow rate decreases gradually	Condensation on measuring tube (might occur with NH ₃ and some hydrocarbons, such as C ₃ H ₈ , C ₄ H ₁₀)	Increase media temperature to above ambient conditions

6.3 Service

For current information about Bronkhorst® and service addresses, please visit our website:

 www.bronkhorst.com

Do you have any questions about our products? Our Sales Department will gladly assist you selecting the right product for your application. Contact sales by e-mail:

 sales@bronkhorst.com

For after-sales questions, our Customer Service Department is available with help and guidance. To contact CSD by e-mail:

 support@bronkhorst.com

No matter the time zone, our experts within the Support Group are available to answer your request immediately or ensure appropriate further action. Our experts can be reached at:

 **+31 859 02 18 66**

Bronkhorst High-Tech B.V.
Nijverheidsstraat 1A
NL-7261 AK Ruurlo
The Netherlands

7 Returns

7.1 Removal and return instructions

When returning materials, always clearly describe the problem, and, if possible, the work to be done, in a covering letter.

Instrument handling:

1. Purge all fluid lines (if applicable)
2. If the instrument has been used with toxic or otherwise hazardous fluids, it must be cleaned before shipping
3. Disconnect all external cabling and tubing and remove the instrument from the process line
4. If applicable, secure movable parts with appropriate transport safety materials, to prevent damage during transportation
5. The instrument must be at ambient temperature before packaging
6. Insert the instrument into a plastic bag and seal the bag
7. Place the bag in an appropriate shipping container; if possible, use the original packaging box

Add documentation:

- Reason of return
- Failure symptoms
- Contaminated condition
- Declaration on decontamination



It is absolutely required to notify the factory if toxic or dangerous fluids have been in contact with the device!
This is to enable the factory to take sufficient precautionary measures to safeguard the staff in their repair department.

All instruments must be dispatched with a completely filled in 'Declaration on decontamination'. Instruments without this declaration will not be accepted.



*A safety information document containing a 'Declaration on decontamination' form (document no 9.17.032) can be downloaded from the **Service & Support** section of the Bronkhorst website (www.bronkhorst.com).*

Important:

Clearly note, on top of the package, the customs clearance number of Bronkhorst High-Tech B.V.:

NL801989978B01

(only if applicable, otherwise contact your Bronkhorst representative for local arrangements.)

7.2 Disposal (end of lifetime)

Within the European Union, manufacturers of electrical and electronic equipment (EEE) are obliged to comply with the WEEE directive (waste electrical and electronic equipment). Bronkhorst offers its customers the possibility to return EEE for disposal at the end of its life, so that it can be properly dismantled and the components recycled or, if possible, reused.

All Bronkhorst® products covered by the WEEE directive (the majority) carry an image of a crossed-out waste bin (usually on the serial number label). If you wish to dispose of Bronkhorst® equipment bearing this symbol, simply return it in accordance with the [removal and return instructions](#), and Bronkhorst will take care of proper dismantling, recycling and/or reuse (wherever possible). In the covering letter, just mention that you are returning the product for disposal. Within the EU, returning products for disposal is of course free of charge (except for shipping and handling costs).



In countries outside the EU, EEE disposal may be subject to local or national directives and/or legislation. If applicable, consult local or national authorities to learn how to handle EEE properly in your area.

Parameter index

Parameters

Parameters - Alarms		Parameters - Master/Slave	
Alarm Delay Time	38	Master Node	46
Alarm Info	38	Slave Factor	47
Alarm Maximum Limit	39	Parameters - Measurement and control	
Alarm Minimum Limit	39	Analog Input	37
Alarm Mode	38	Density Actual	36
Alarm New Setpoint	39	Fmeasure	36
Alarm Setpoint Mode	39	Fsetpoint	37
Reset Alarm Enable	39	Measure	36
Parameters - Controller		Pressure	36
Controller Speed	47	Sensor Type	37
Normal step response	48	Setpoint	36
Open from zero response	48	Setpoint Slope	37
PID-Kp	48	Temperature	36
PID-Td	48	Valve Output	37
PID-Ti	48	Parameters - Network configuration	
Stable situation response	48	Fieldbus1 Address	41
Parameters - Counter		Fieldbus1 Baud Rate	41
Counter Limit	40	Fieldbus1 Parity	42
Counter Mode	39	Fieldbus2 Address	42
Counter New Setpoint	40	Fieldbus2 Baud Rate	42
Counter Setpoint Mode	40	Fieldbus2 Parity	42
Counter Unit	40	Parameters - Special	
Counter Value	40	Control Mode	43
Reset Counter Enable	41	Init Reset	42
Parameters - Device identification		IO Status	44
BHT Model Number	35	Reset	43
Customer Model	35	Wink	43
Device type	35		
Firmware version	35		
Identification number	35		
Serial Number	35		
User Tag	35		
Parameters - Fluid set			
Capacity	45		
Capacity Unit	45		
Capacity Unit Type Pressure	45		
Capacity Unit Type Temperature	45		
Fluid Name	44		
Fluid Set Index	44		
Parameters - Fluid set (advanced)			
Density	46		
Fluid Temperature	46		
Inlet Pressure	45		
Outlet Pressure	46		